

IMPORTANT:
KEEP THESE INSTRUCTIONS FOR
FUTURE REFERENCE.

**PACIFIC
ENERGY**

VISTA LE2

INSTALLATION AND OPERATING INSTRUCTIONS - AUSTRALIA

AUSTRALIA

SERIAL #



SAFETY NOTICE

If this stove is not properly installed, a house fire may result. For your safety, follow the installation instructions. Contact local building or fire officials about restrictions and installation inspection requirements in your area.

MODEL:

VISTA LE2

Contents

Contents	2
Safety and Maintenance	3
Maintenance Checks	4
Creosote.....	5
Crate Removal.....	6
Leg (Optional) installation.....	6
Appliance Dimensions	6
Assembly	6
Optional Ash Cleanout installation.....	7
Installation	7
Flue Gas Agitator Removal/Installation.....	8
Installing the Flue Thermocouple Guard	9
Optional Battery Box Installation.....	10
Floor Protector.....	11
Back Wall Clearances	11
Clearances.....	11
Chimney and Connector.....	12
Installation Procedure -Residential	12
Firebrick Installation.....	13
Combustion Air	17
Wood Selection	18
Operation	18
How to Test Your Wood.....	19
Lighting for the First Time	19
Lighting a Fire.....	19
Normal Operation	19
Restarting After Extended or Overnight Burns.....	20
Proper Draft	20
Ash Removal.....	20
Disposal of Ashes.....	20
Baffle Removal.....	21
Troubleshooting	22
Parts Diagram - VISTA LE2	23
Compliance Plate.....	25

NOTE:

WE STRONGLY RECOMMEND THAT SMOKE DETECTORS BE INSTALLED.

If smoke detectors have been previously installed, you may notice that they are operating more frequently. This may be due to curing of stove paint or fumes caused by accidentally leaving the fire door open. Do not disconnect the detectors. If necessary, relocate them to reduce their sensitivity.

SAFETY NOTICE:

If this stove is not properly installed, a house fire may result. For your safety, follow the installation instructions. Contact local building or fire officials about restrictions and installation inspection requirements in your area.

Please read this entire manual before you install and use your new room heater. Failure to follow instructions may result in property damage, bodily injury, or even death.

Safety and Maintenance

1. Burn cord wood only, dry well seasoned wood. The denser or heavier the wood when dry, the greater its heat value. This is why hardwoods are generally preferred. Green or wet wood should not be used, as it will reduce heat output, as well as contributing significantly to creosote buildup.
2. Remove ashes frequently and only when the stove is cold. Too much ash could cause embers to roll out the door when it is opened. This may pose a fire hazard. For proper operation, maintain a 25mm minimum ash base.
3. If glass becomes darkened from slow burning or poor wood, it can readily be cleaned with fireplace glass cleaner when stove is cold. Never scrape with an object or use abrasive cleaners that might scratch the glass. The type and amount of deposit on the glass is a good indication of the flue pipe and chimney buildup. A light brown dusty deposit that is easily wiped off usually indicates good combustion and dry, well-seasoned wood, therefore relatively clean pipes and chimney. On the other hand, a black greasy deposit that is difficult to remove is a result of wet and green wood and too slow a burning rate. This will also create heavy deposit buildup in the chimney.
4. **DOOR GASKETS** - The gasket used by Pacific Energy (22 mm medium density fibreglass rope) requires only light pressure to seal. This will prolong seal life. It is important that the door seal be maintained in good condition. Periodically inspect seals and replace if necessary. Follow instructions included in the door gasket kit obtainable from your nearest Pacific Energy dealer.
5. **DOOR GLASS** - Do not slam loading door or otherwise impact glass. When closing door, make sure that no logs protrude to impact the glass. If the glass gets cracked or broken, it must be replaced before using the stove. Replacement glass can be obtained from your dealer. Use ceramic glass only. Do not substitute with any other type.

GLASS SIZE - 266mm x 419mm x 5mm thick.

To remove broken glass, undo the four retaining screws and remove clamps, noting position for re-assembly. Remove all particles of glass. Be careful as they are very sharp. Install new glass complete with gasket. Replace clamps and screws.
6. Do not store wood within heater installation clearances, or within the space required for fuel loading and ash removal. Keep the area around the heater clean and free of loose combustibles, furniture, newspapers, etc...
7. If the heater requires cleaning, use mild soap and water only. Use of abrasive cleaners will void warranty.
8. Establish a routine for fuelling and firing the heater. Check daily for creosote buildup until experience shows how often you need to clean the chimney to be safe.
9. Be aware that the hotter the fire, the less creosote is deposited. Weekly cleaning may be necessary in mild weather, even though monthly cleaning is usually enough in the coldest months when burning rates are higher.
10. Instruct all members of your family on the safe operation of the heater. Ensure they have enough knowledge of the entire system if they are expected to operate it. Study the section on chimney fires and the importance of following the steps outlined "In Case of Chimney Fire".

WARNING:

Never use chemicals or any other volatile liquid to start a fire. Do not burn garbage, or flammable fluids such as gasoline, naphtha, or engine oil. We strongly recommend that smoke detectors be installed.

WARNING:

Only use materials supplied by manufacturer when doing maintenance or replacements.

CAUTION:

- Tighten screws very carefully, do not over-tighten
- Do not clean glass when hot
- Do not use abrasive cleaners on glass



Maintenance Checks

Check the following parts for damage such as cracks, excessive corrosion, burned out sections and excessive warping**: (See website for descriptions and more detail)

Weekly:

- Firebrick - Visual, for cracking.
- Door Gasket - sagging, placement, damage.

Monthly

- Brick rail tabs and brick rails.
- Air riser tube in the back of the firebox.
- Back side of airwash chamber.
- Baffle locking pin.
- Baffle Tubes.

When Cleaning the Chimney System:

- Top baffle board/blanket.
- Baffle/Baffle Tubes.
- Top heat shield and mounting bolt.
- Baffle Gasket.
- Brick Rails.

** - Some warping of the baffle is normal (up to 0.65 cm).

- Replace if the baffle has permanent warping greater than this or has cracking or breakage.
- Please contact your Dealer if you experience any of the damage listed above. Continuing to operate your stove with broken parts may accelerate damage to other parts and may void your warranty

Formation and Need for Removal

When wood is burned slowly, it produces tar and other organic vapours, which combine with expelled moisture to form creosote. The creosote vapours condense in the relatively cool chimney flue of a slow burning fire. As a result, creosote residue accumulates on the flue lining. When ignited, this creosote makes an extremely hot fire.

The chimney connector and chimney should be inspected periodically (at least once every two months) during the heating season to determine if a creosote buildup has occurred. If creosote has accumulated (3 mm. or more), it should be removed to reduce the risk of a chimney fire.

1. Highest smoke densities occur when a large amount of wood is added to a bed of hot coals and the air inlet is closed. The heated wood generates smoke, but without ample air, the smoke cannot burn. Smoke-free, clean burning requires leaving the air inlet relatively wide open, especially during the first 10 to 30 minutes after each loading, when most of the smoke generating reactions are occurring. After 30 minutes or once the wood is fully charred, the air inlet can be turned down substantially without excessive smoke generation. Wood coals create very little creosote-producing smoke.
2. The cooler the surface over which the wood smoke is passing, the more creosote will be condensed. Wet or green wood contributes significantly to creosote formation as the excess moisture that is boiled off cools the fire, making it difficult for the tars and gases to ignite, thus creating dense smoke and poor combustion. This moisture-laden smoke cools the chimney, compounding the problem by offering the smoke the ideal place to condense.

In summary, a certain amount of creosote is inevitable. Regular inspection and cleaning is the solution. The use of dry, seasoned wood and ample combustion air will help to minimize the buildup. Excessive creosote build-up can cause a chimney fire

Avoiding a Chimney Fire

1. Keep your chimney clear of creosote build-up by cleaning your chimney before each burn season, and as necessary (accumulations of 3 mm or more) during the season.
2. Burn clean, well-seasoned wood only (seasoned at least one year). Avoid wet or green wood.
3. Do not burn household trash, cardboard, plastics, construction lumber, treated or beach wood (as these will corrode your fireplace and void your warranty).
4. Do not leave the air inlet wide-open for extended periods of time.
5. Keep a fire extinguisher handy.
6. Prepare a home evacuation plan with a place outside where everyone is to meet.

Signs of a Chimney Fire

May be one or more of the following:

- A roaring sound.
- Vibration of the chimney.
- Flames and sparks shooting out of the top of the chimney.

In Case of a Chimney Fire

1. Immediately close the air inlets on the stove.
2. Evacuate the home, and call the local fire department.
3. After the chimney fire has been extinguished, the chimney must be cleaned and checked for stress and cracking before starting another fire. Also check combustibles around the chimney and roof.

Appliance Dimensions

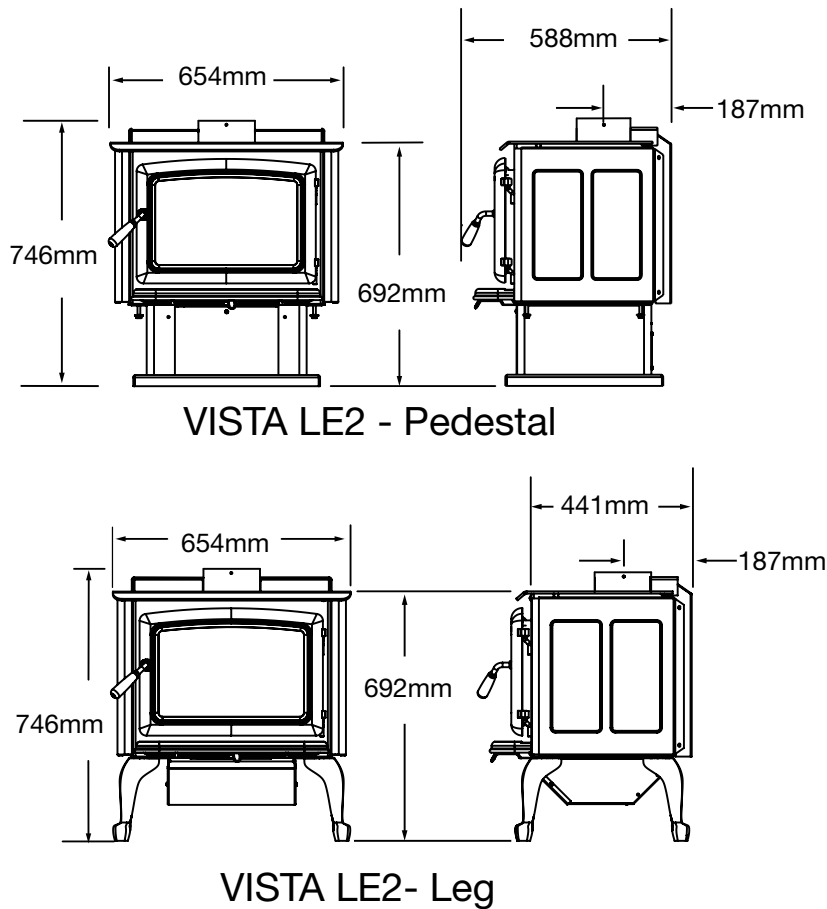

Figure 1. Vista, Classic metric dims.

Assembly

Crate Removal

1. Carefully remove wood top and supports. Remove plastic cover.
2. Using a 7/16" wrench, remove lag bolts that secure the stove body to pallet
 - Pedestal: remove the bolts from the pedestal base then lift the unit up and off of the pallet.
 - Legs: Place the unit on its back. Using a 3/4" wrench, loosen the 4 nuts located at the corners of the base. Remove the pallet retaining brackets.

Leg (Optional) installation

Leg Installation: insert the leg between the washer and the "Leg Adapter". Square the leg to the firebox bottom and tighten the nut, then move to the next leg

Optional Ash Cleanout installation

1. Locate the two nuts under the firebox holding the ash system (hole) cover and gasket. Remove the nuts, leaving the bolts in place. Discard the cover plate and gasket.
2. Remove any tabs as needed where the Ash Cleanout rod will be on the left side.
3. Place the new gasket on the Ash Dump assembly
4. Install Ash Cleanout system with gasket up, from under the firebox securely on the two bolts with the two nuts previously removed.

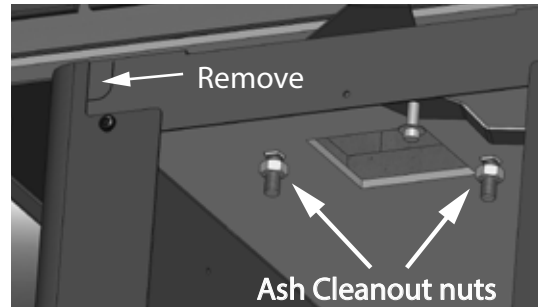

Figure 2. Ash Cleanout install.

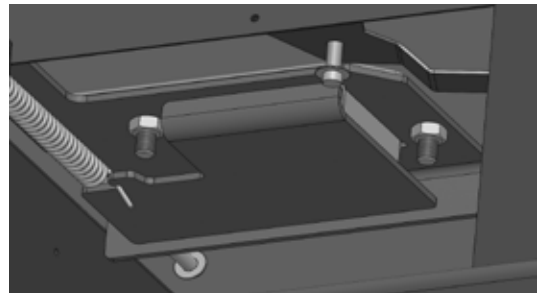

Figure 3. Ash Cleanout Install 2.

Installation

Warning:

Under no circumstances is this heater to be installed in a makeshift or "temporary" manner. It may be fired only after the stove is installed properly.

DO NOT ATTEMPT TO CONNECT THIS HEATER TO ANY AIR DISTRIBUTION DUCT.

Outside combustion air or fresh air into the room may be required in your area, consult local building codes (see Combustion Air section).

WARNING: THE APPLIANCE AND FLUE-SYSTEM SHALL BE INSTALLED IN ACCORDANCE WITH AS/NZS 2918 AND THE APPROPRIATE REQUIREMENTS OF THE RELEVANT BUILDING CODE OR CODES

WARNING: APPLIANCES INSTALLED IN ACCORDANCE WITH THIS STANDARD SHALL COMPLY WITH THE REQUIREMENTS OF AS/NZS 4013 WHERE REQUIRED BY THE REGULATORY AUTHORITY, I.E. THE APPLIANCE SHALL BE IDENTIFIABLE BY A COMPLIANCE PLATE WITH THE MARKING 'TESTED TO AS/NZS 4013'.

ANY MODIFICATION OF THE APPLIANCE THAT HAS NOT BEEN APPROVED IN WRITING BY THE TESTING AUTHORITY IS CONSIDERED TO BE IN BREACH OF THE APPROVAL GRANTED FOR COMPLIANCE WITH AS/NZS 4013.

CAUTION: MIXING OF APPLIANCE OR FLUE-SYSTEM COMPONENTS FROM DIFFERENT SOURCES OR MODIFYING THE DIMENSIONAL SPECIFICATION OF COMPONENTS MAY RESULT IN HAZARDOUS CONDITIONS. WHERE SUCH ACTION IS CONSIDERED, THE MANUFACTURER SHOULD BE CONSULTED IN THE FIRST INSTANCE.

CAUTION: CRACKED OR BROKEN COMPONENTS, e.g. GLASS PANELS OR CERAMIC TILES, MAY RENDER THE INSTALLATION UNSAFE.

WARNING: ANY MODIFICATION OF THE APPLIANCE THAT HAS NOT BEEN APPROVED IN WRITING BY THE TESTING AUTHORITY IS CONSIDERED AS BREACHING AS/NZS 4013.

CAUTION: THIS APPLIANCE SHOULD NOT BE OPERATED WITH A CRACKED GLASS.

CAUTION: THIS APPLIANCE SHOULD BE MAINTAINED AND OPERATED AT ALL TIMES IN ACCORDANCE WITH THESE INSTRUCTIONS.

CAUTION: THE USE OF SOME TYPES OF PRESERVATIVE-TREATED WOOD AS A FUEL CAN BE HAZARDOUS.

Flue Gas Agitator Removal/Installation

DO NOT OPERATE WITH AGITATOR REMOVED.

The Flue Gas Agitator comes pre-installed inside the unit and should not need to be handled in any way. In the case the Agitator needs to Be replaced, follow the instructions below.

Removal

1. Remove the rear baffle assembly. Figure 4 See "Baffle Removal" page 21.
2. Lift the Flue Gas Agitator and pull towards the front of the stove Figure 5



Figure 4. Remove rear baffle



Figure 5. Remove Flue Gas Agitator

3. Lower the Flue Gas Agitator down and disengage it from the front mounting slots in the flame shield. Figure 6
4. Reverse Steps 1-3 to install the new Flue Gas Agitator.



Figure 6. Front mounting slots for Flue Gas Agitator

Installing the Flue Thermocouple Guard

1. Remove the thermocouple guard from inside the flue collar of the unit. Figure 7
2. Remove the piece of cardboard holding the flue gas agitator in place. Figure 8
3. Re-install the thermocouple guard. Ensure all three ends are in place correctly. Figure 9



Figure 7. Thermocouple guard.

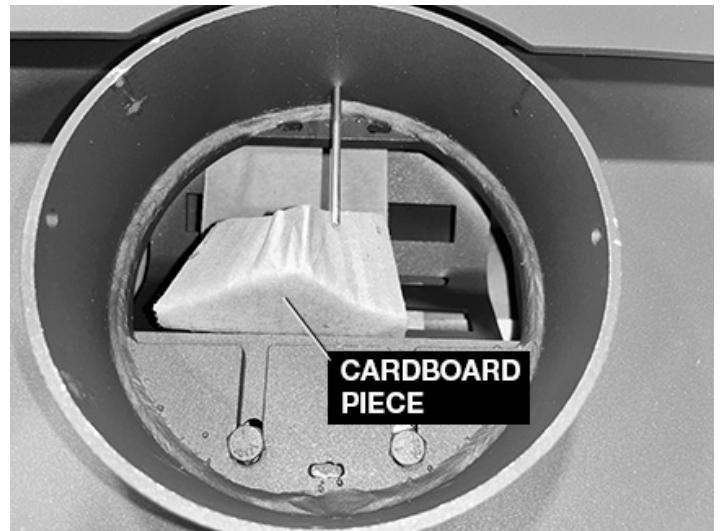

Figure 8. Cardboard piece.

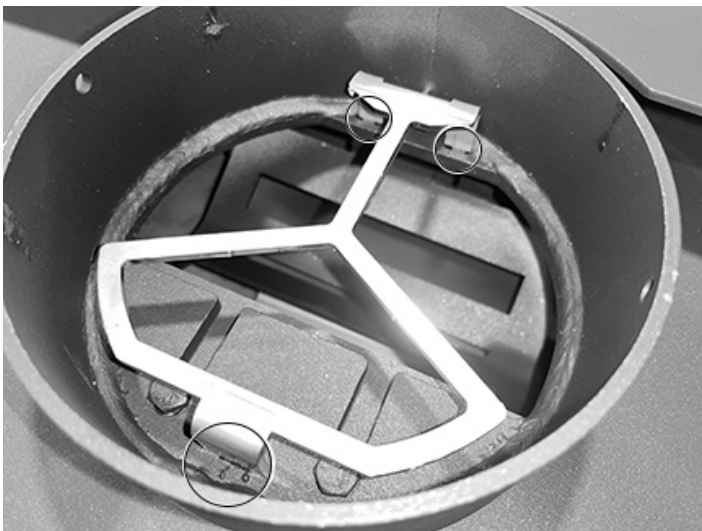

Figure 9. Thermocouple guard installed.

Connecting the A/C Adapter

Remove the A/C Adapter from inside the unit and connect the barrel plug to A/C Adapter plug in the Control Board then connect the adapter to a wall outlet. Figure 10

NOTE: If you unplug the unit for any reason, unplug the adapter from the wall outlet and wait a minimum of 30 seconds before plugging the unit back in. Also, if the power to the unit flickers, the control board may freeze up. Unplug the A/C Adapter from the wall for a minimum 30 seconds before plugging it back in to reset the control board.

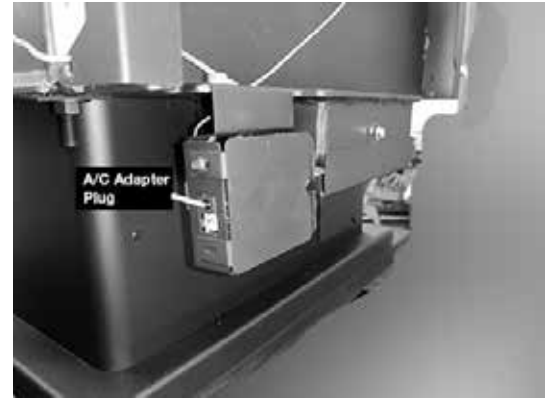

Figure 10. A/C Adapter plug.

NOTE: BATTERIES WILL LAST AN ESTIMATED 5-7 DAYS UNDER CONTINUOUS USE.

Optional Battery Box Installation

1. Remove the Battery Box from the packaging.
2. Connect the plug from the Battery Box to the connection on the right side of the Control Board. (Right is "your right" and determined when standing facing the front of the unit.)
3. Put the #8 X 1/2" screw provided into the hole in the bottom flange of the right side panel.
4. Hook the top flange of the Battery Box inside the right panel engaging the screw in the bottom flange of the right side panel into one of the holes. (Right is "your right" and determined when standing facing the front of the unit.)

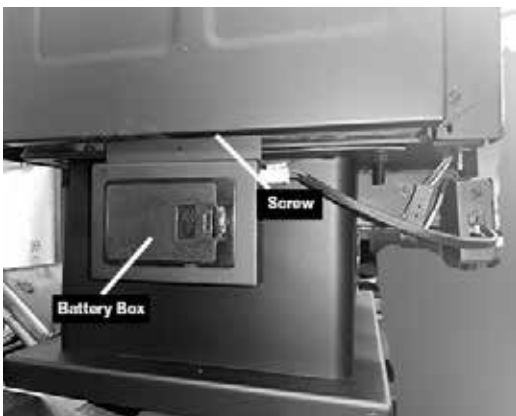

Figure 11. Battery Box.



Figure 12. Battery Box plug.

Changing the Batteries

The Battery Box Assembly is located on the right side of the unit, below the side panel, if standing, facing the front of the unit. The Battery Box Assembly is secured to the firebox with a screw and can be easily lowered and held to change the batteries. **Note: Be careful not to pull on the wires connecting the Battery Box to the Control Board.**

1. Carefully lower the Battery Box so the battery cover is facing up.
2. Remove the battery cover by releasing the catch at the end and lifting the cover off.
3. Remove the old batteries and replace them with the new ones.
4. Replace the battery cover and re-engage the flange onto the screw in the side panel again.

OPTIONAL BATTERY BACKUP: In the event of a power failure, the appliance is fully functional when using their optional battery backup system.

POWER FAILURE: In the event of complete power failure, until power is restored or batteries are replaced, the appliance will still operate within safe and certified limits using the manual air control at the front of the unit.

Clearances

Minimum Clearance to Combustibles

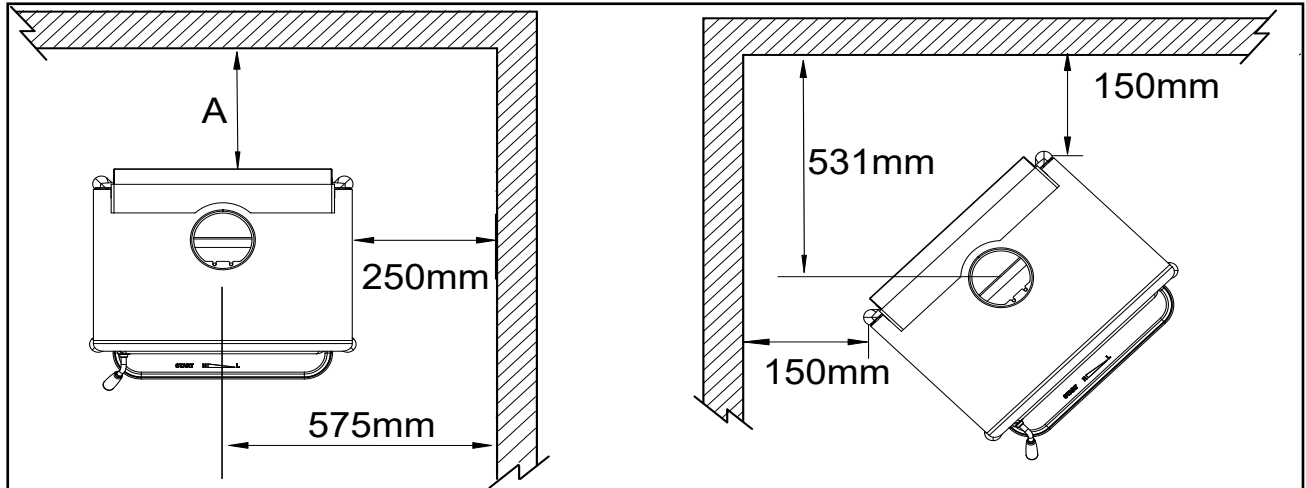

Figure 13. Vista AS - Clearances.

Back Wall Clearances

A. **320mm** when using a Dacromesh Shield only.

120mm when installed with a 130degree x 900mm stainless steel flue shield between the dacromesh casing and active flue

Floor Protector

The stove may be installed on a combustible floor provided ember protection made from a 9mm thick non-combustible material (Bellis Board) with a thermal conductivity value of .1w/m degree K.

This protection must extend as follows:

300mm on the firing side and 200mm both sides of the door opening. See Figure #5.

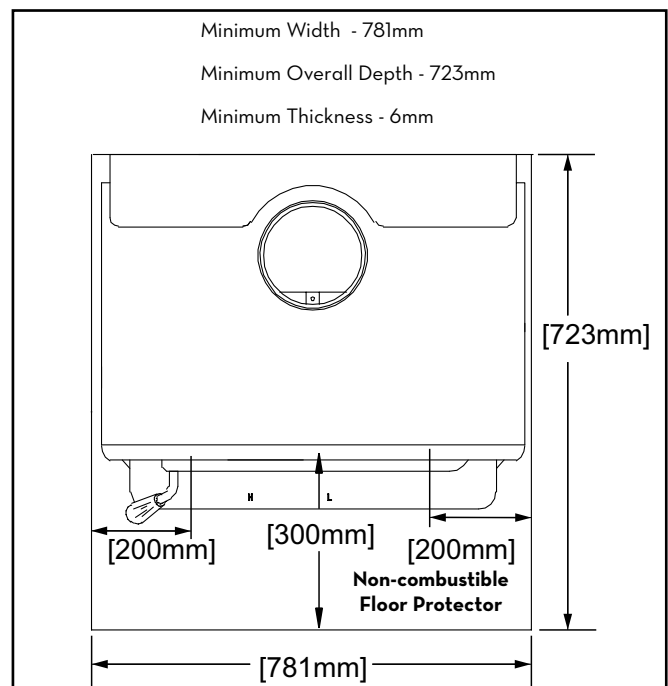

Figure 14. Floor Protector Vista LE2

Chimney and Connector

WARNING: INSTALL CHIMNEY AND ALL COMPONENTS OF CHIMNEY SYSTEM ACCORDING TO CHIMNEY MANUFACTURER'S INSTRUCTIONS.

Connect to a listed chimney complying with the requirements of AS/NZS2918/2001 and a chimney suitable for use with solid fuel that is lined and in good condition and meets local building codes. The chimney flue size should be the same as the stove outlet for optimal performance. Reducing or increasing the flue size may adversely affect stove performance. Chimney flue exit is to be minimum 100 cm above roof and 60 cm above highest projection within 300 cm. The installation must meet all local codes. Do not connect this unit to a chimney flue serving another appliance. Minimum system height is 460 cm (measured from base of appliance).

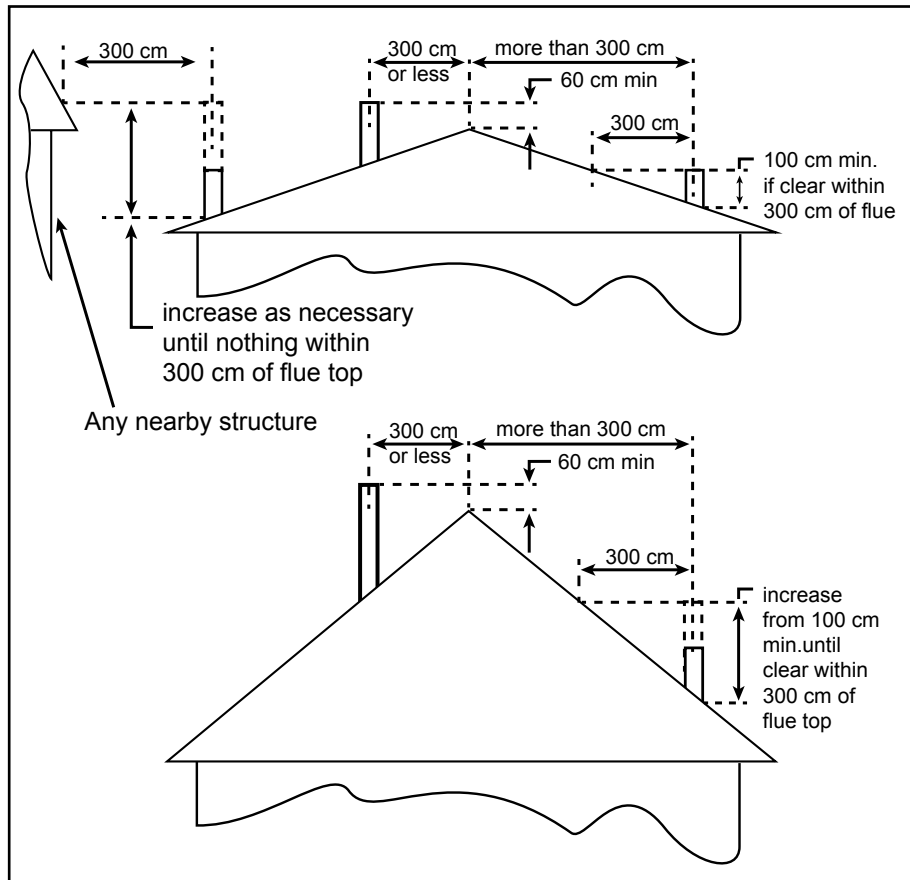

Figure 15. Chimney and connector

Installation Procedure -Residential

1. Install all components to the chimney manufacturer's installation requirements. (Outside combustion air may be required, consult local building codes. See Combustion Air section on page 17.)
2. Installed with the crimped or male ends pointing down. This will carry any liquid creosote or condensation back into the stove.
3. If a roof or ceiling support is used in the installation, you will find the chimney manufacturer's complete instructions packed with the roof support.
4. To start installing smoke pipe (chimney connector), slip crimped edge of the pipe inside the stove collar. Use holes provided in collar to secure pipe with three screws.
5. Install the remaining lengths of pipe, one on top of the other, to the finished height of the chimney connector and secure to each other.

Firebrick Installation

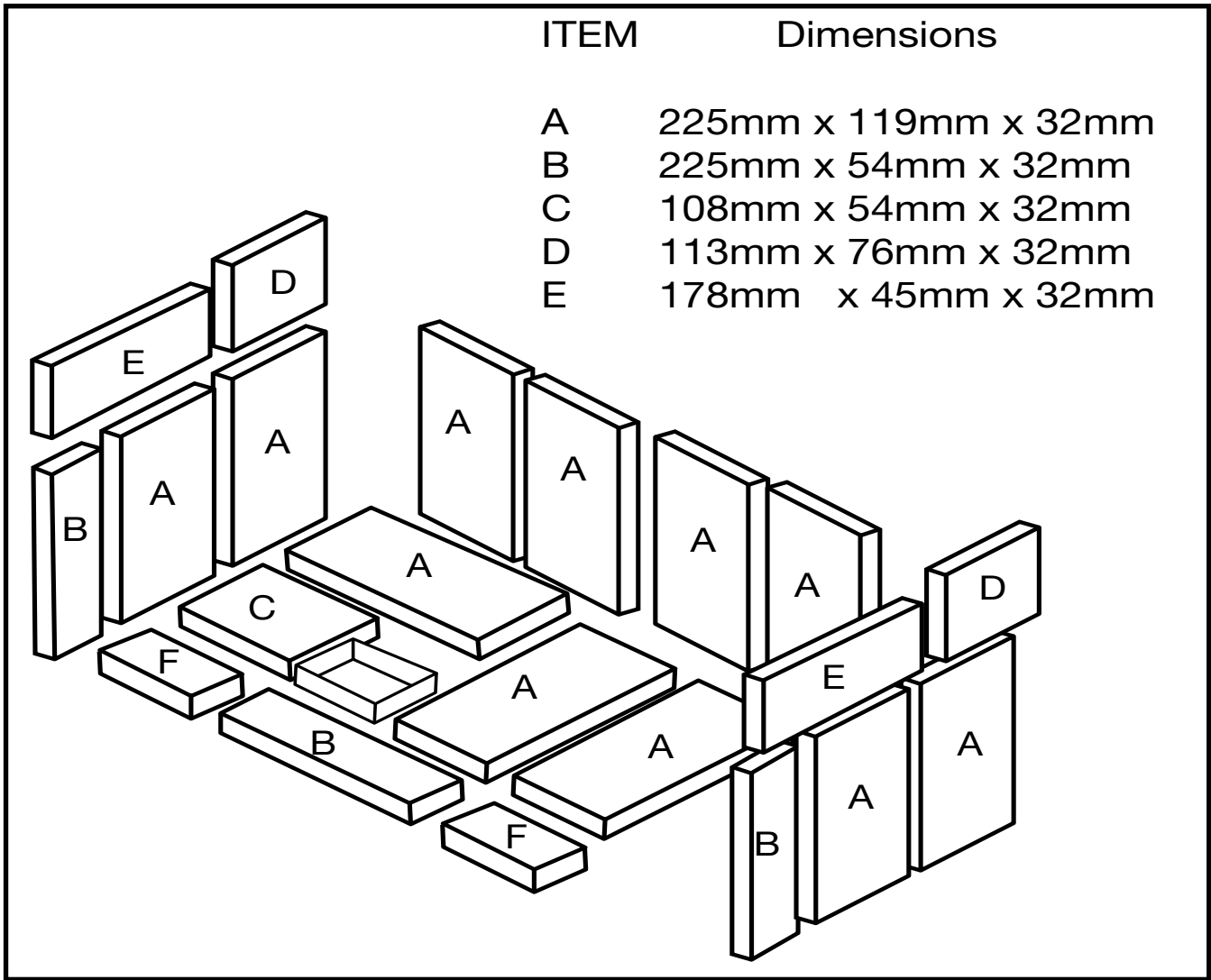

Figure 16. Vista LE2 Firebrick.

Begin firebrick installation with the rear wall.

1. Stand one "A" firebrick vertically behind the tab located on the brick rail. Slide the firebrick toward the center of the rear wall Figure 17.
2. Slide a 2nd "A" firebrick underneath the tab on the brick rail Figure 18.

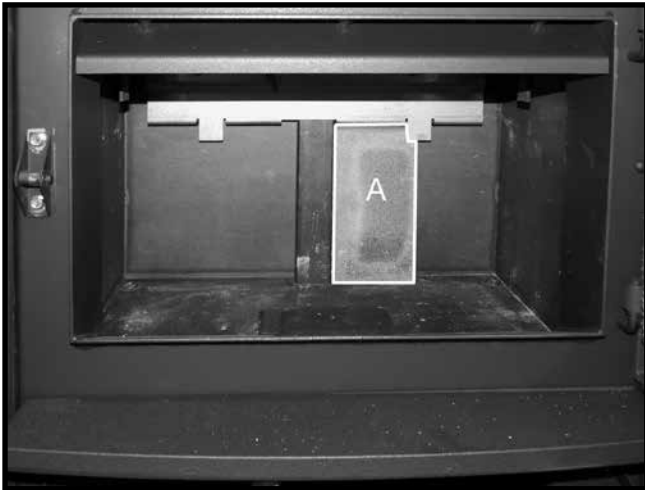

Figure 17. Installing the 1st of the rear wall bricks

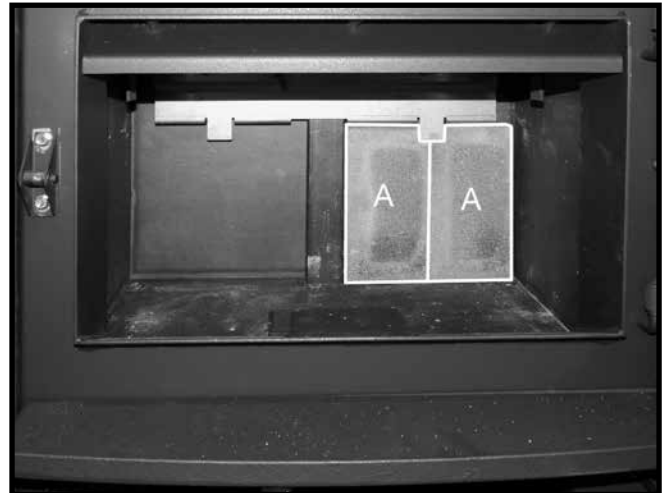

Figure 18. Installing the 2nd of the rear wall bricks

3. Repeat steps 1 & 2 for the placement of the other "A" firebricks on the rear wall Figure 19.
4. For the side walls: Slide a "D" firebrick up into the back corner of the firebox then, while holding it in place, stand an "A" firebrick against the side wall under the "D" firebrick and up against the rear wall firebrick Figure 20.

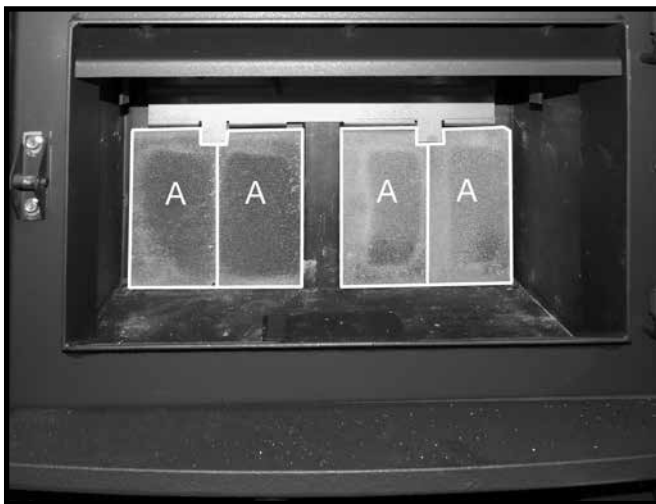

Figure 19. Remaining rear wall firebricks in place.

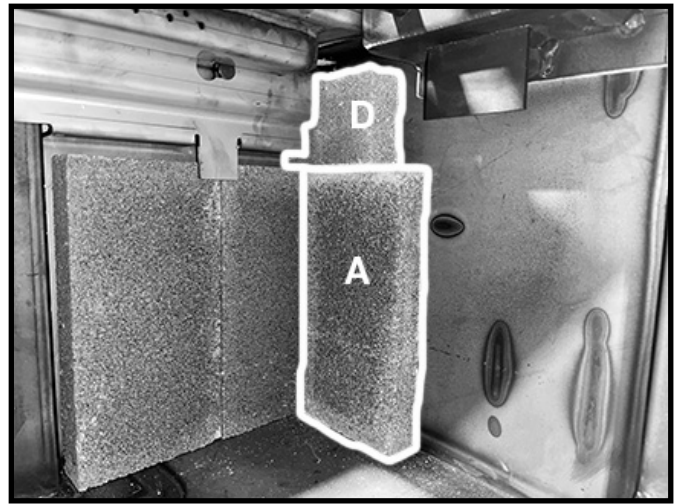

Figure 20. 1st side wall bricks in place.

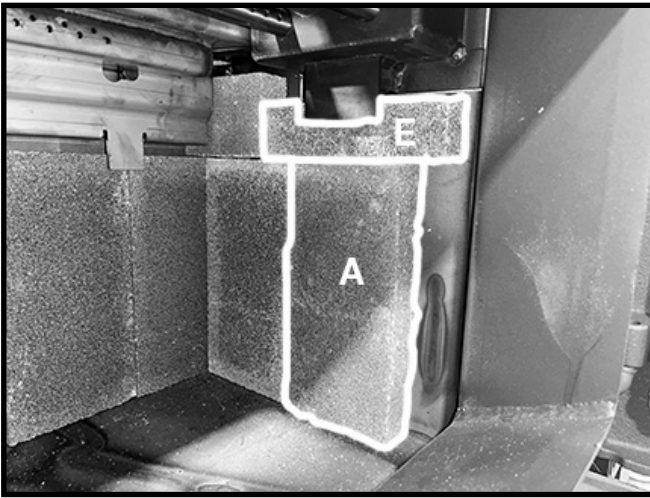

Figure 21. Second side wall bricks in place.

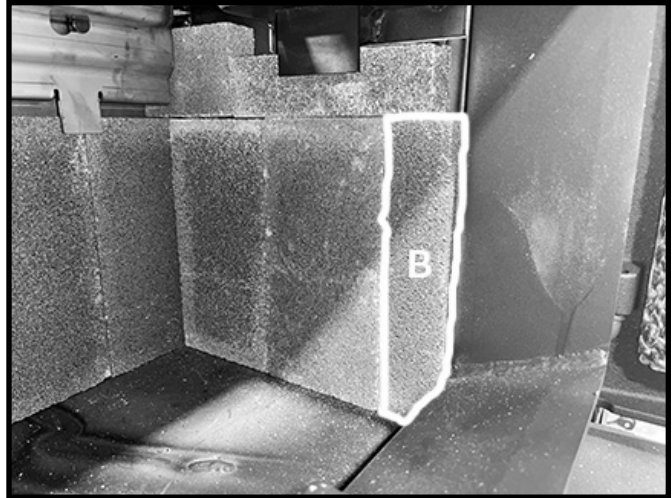

Figure 22. Front side wall firebricks in position.

5. Next, place an "E" firebrick up under the side brick retainer tab and stand another "A" brick beside the first one under the "E" firebrick Figure 21.
6. Place a "B" firebrick under the "E" firebrick and against the side wall of the firebox Figure 22.
7. Repeat steps 4-6 on the other side Figure 23.

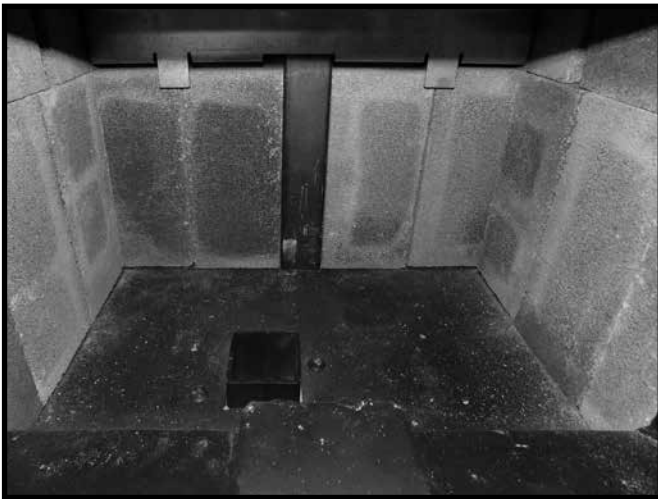

Figure 23. Firebox floor with ash dump.

8. Units with Ash Dump installed:
 - Place two "A" firebricks on the firebox floor as shown in Figure 24. on page 16
 - Place a third "A" firebrick against the rear wall as shown in Figure 25. on page 16
 - Place the "C" firebrick so that it sits beside the ash dump, against the left-hand side wall and the "A" firebrick located directly behind the ash dump Figure 26. on page 16
9. Units without Ash Dump installed:
 - Place 4 "A" firebricks on the firebox in the same direction as the bricks in Figure 24 . Push bricks to the back of the firebox.

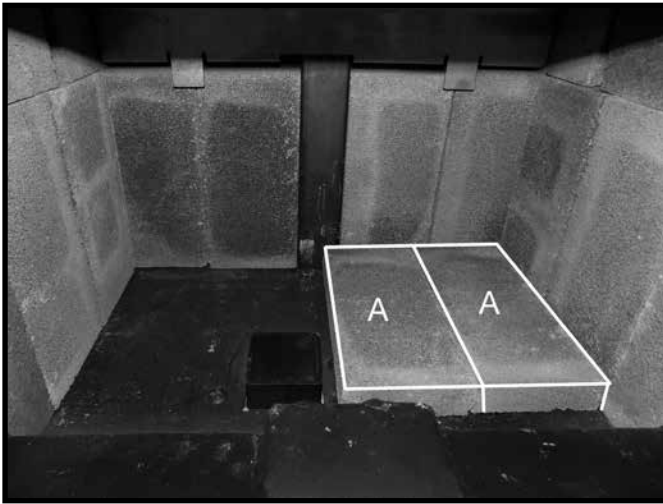

Figure 24. First two floor bricks in place.

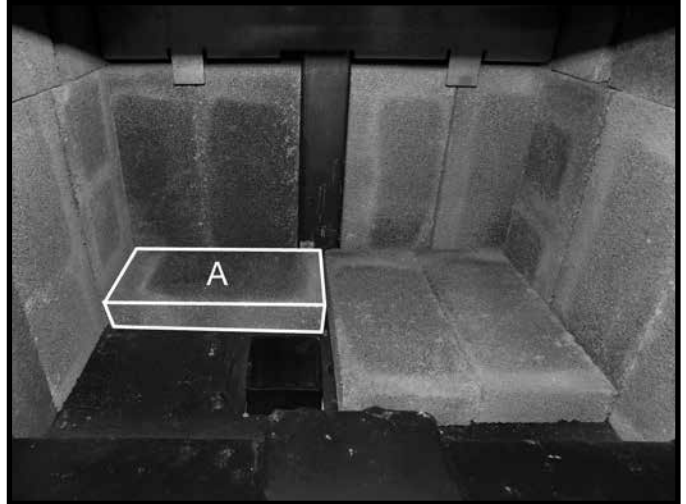

Figure 25. Third floor brick in place.

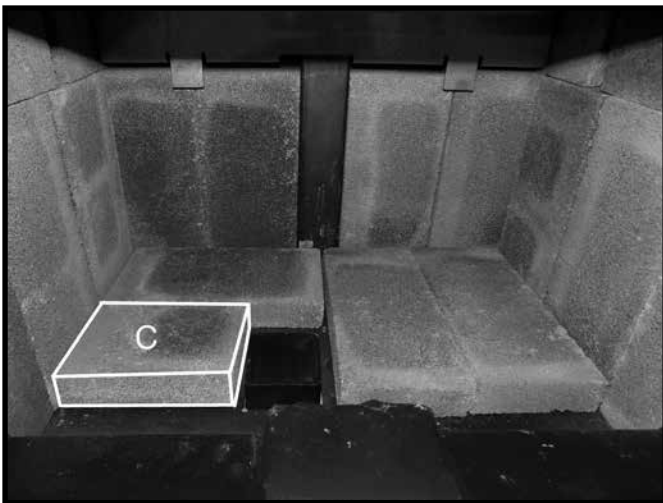

Figure 26. Fourth floor brick in place.

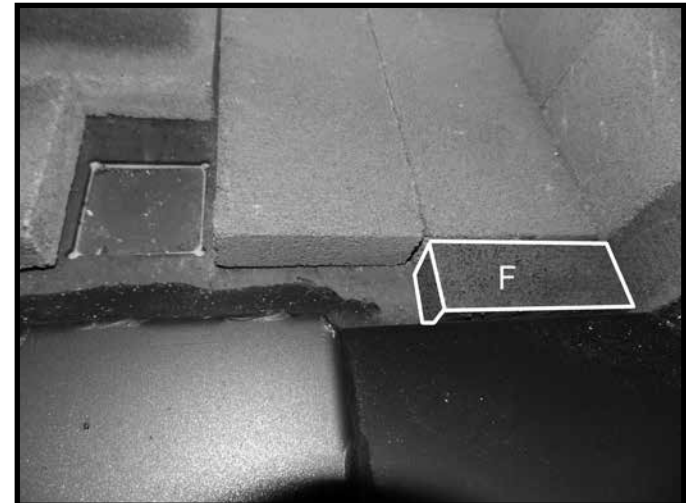

Figure 27. Short, narrow brick installed in front row.

10. Place a short narrow "F" brick against the front right side of the floor (Figure 27) followed by a longer "B" brick in the center of the front row (Figure 28). Finish with the last "F" brick placed against the left side front row (Figure 29).
Note: There will be a gap remaining behind the ash dump.

Note: there will be one brick left over as a spare for units with an ashdump.

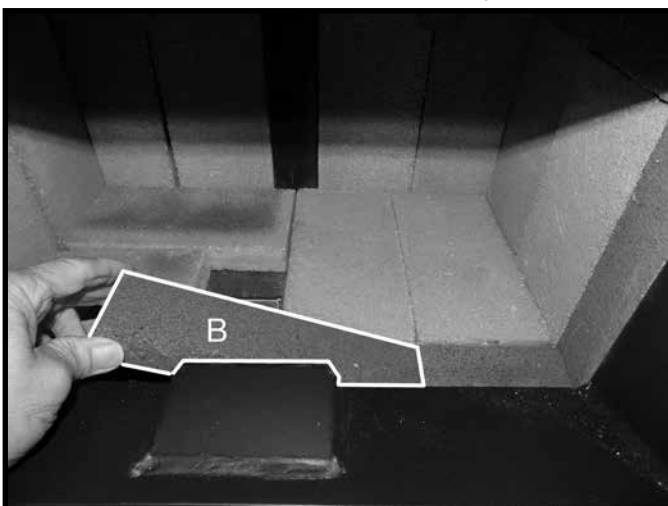

Figure 28. Long, narrow center brick in front row.

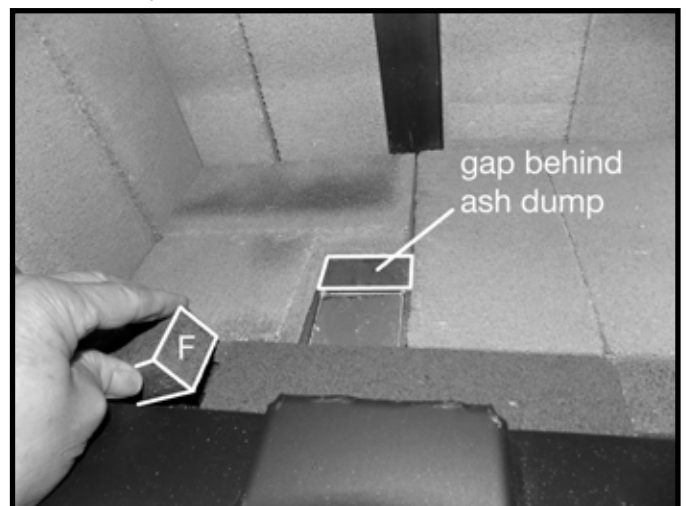

Figure 29. Final short, narrow brick in front row.

Combustion Air

Intake or combustion air can be supplied to the stove in one of two ways. Consult your local building code or Installation Code for Solid-Fuel-Burning Appliances and Equipment before proceeding.

1. **Outside air supply** - (Necessary for air tight homes.) Outside air may be drawn from either underneath the stove or from behind.

To draw outside air through the floor, leave the 100mm knockout or cover plate in place in the rear of the pedestal or leg kit ash box enclosure.

Pedestal Model: Cut or drill a 100mm diameter hole in the floor anywhere inside the perimeter of the pedestal. Cover the hole with a 100mm x 100mm rodent screen and staple/nail in place.

Leg Model: Cut or drill a 100mm diameter hole in the floor below the hole in the back of the ash box enclosure. Connect enclosure to the floor with a short 100mm diameter pipe.

This hole must get its air from a **ventilated** crawl space or be extended with duct to the outdoors (see Figure #30). The use of outside combustion air for residential installation requires the unit to be secured to the structure to prevent dislodging of the air duct.

To draw outside air from behind the stove, an outside air adaptor may be required cut or drill a 100mm hole through a wall behind the unit. Use an appropriate household 100mm inlet. You must remove the rear cover plate from the pedestal or move the cover plate at the rear of the leg kit ash box enclosure to cover the bottom hole.

Note: This unit is not designed to be operated with the firing door open. In addition to the obvious hazard of sparks landing on combustibles, an open fire door will cause the heater to draw air from the living space and possibly cause suffocation.

1. **Room air supply** - Remove the cover plate from the rear of the pedestal or leg kit ash box enclosure. The stove will now draw its air from the room through this opening and into the firebox intake.

Note: The living space around the heater must be well ventilated with good air circulation. Anything that may cause a negative pressure can cause gases or fumes to be pulled into the living area. During extremely cold weather, and especially when burning at very slow rates, the upper parts of the exposed chimney may ice up, partially blocking the flue gases. If blockage occurs, flue gases may enter living space.

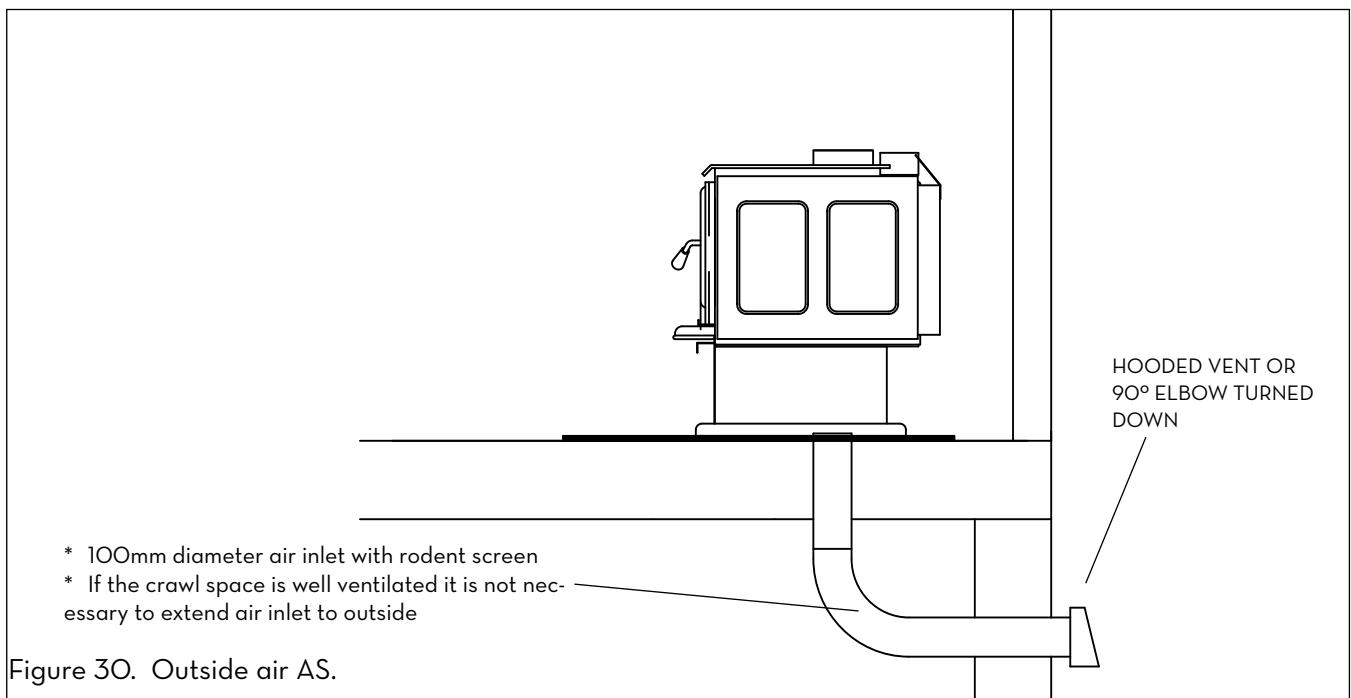

Operation

CAUTION:

Never use gasoline, gasoline type lantern fuel, kerosene, charcoal lighter fluid or similar liquids to start or "freshen up" a fire in this heater. Keep all such liquids well away from the heater while it is in use.

CAUTION:

Hot while in operation. Keep children, clothing and furniture away. Contact may cause skin burns.

WARNING: DO NOT USE FLAMMABLE LIQUIDS OR AEROSOLS TO START OR REKINDLE THE FIRE.

WARNING: DO NOT USE FLAMMABLE LIQUIDS OR AEROSOLS IN THE VICINITY OF THIS APPLIANCE WHEN IT IS OPERATING.

WARNING: DO NOT STORE FUEL WITHIN HEATER INSTALLATION CLEARANCES.

WARNING: DO NOT OPERATE THIS APPLIANCE AS AN OPEN FIRE.

WARNING: OPEN AIR CONTROL (AND DAMPER WHEN FITTED) BEFORE OPENING FIRING DOOR.

Your PACIFIC ENERGY heater is designed for maximum overall efficiency at a moderate firing rate. Overfiring is hazardous and a waste of fuel. Too slow a burn contributes to creosote buildup and lowers combustion efficiency.

NOTE: Left and Right as referred to in this manual are considered your left and right when facing the front of the woodstove.

Wood Selection

This heater is designed to burn natural wood only. Higher efficiency and lower emissions generally result when burning air-dried seasoned hardwoods, as compared to softwoods or too green or freshly cut hardwoods.

Wood should be properly air dried (seasoned) for six months or more. Wet or undried wood will cause the fire to smoulder and produce large amounts of creosote. Wet wood also produces very little heat and tends to go out often.

DO NOT BURN :

- Salt water wood *
- Treated wood
- Wet or green wood
- Coal/charcoal
- Garbage/Plastic *
- Solvents

* These materials contain chlorides which will rapidly destroy metal surfaces and void warranty.

Do not burn anything but wood. Other fuels (eg. charcoal) can produce large amounts of carbon monoxide, a tasteless, odourless gas that can kill. Under no circumstances should you attempt to barbecue in this heater.

How to Test Your Wood

Add a large piece of wood to the stove when it has a good large bed of coals. It is dry if it is burning on more than one side within one minute. It is damp if it turns black and lights within three minutes. If it sizzles, hisses and blackens without igniting in five minutes it is soaked and should not be burnt.

Lighting for the First Time

Curing of the Paint Finish

To achieve the best finish, the paint on your stove must be baked on. When burning your stove for the first 2-3 times it is very important that the room be well ventilated. Open all windows and doors. Smoke and fumes caused by the curing process may cause discomfort to some individuals.

Lighting a Fire

WARNING: Never use chemicals or any other volatile liquid to start a fire.

1. Adjust air control to maximum firing position (start position) and open door.
2. Place crumpled newspaper in the centre of the heater and criss-cross with several pieces of dry kindling. Add a few small pieces of dry wood on top.
3. Ignite the paper and close the door.
4. After the fire has established itself, open the door and add a few small logs. Close the door.
5. Begin normal operation after a good coal base exists and wood has charred.

Normal Operation

1. Set air control to a desired setting. If smoke pours down across the glass (waterfall effect) this indicates you have shut the control down too soon or you are using too low a setting. As every home's heating needs vary (based on insulation, windows, climate, etc.) the proper setting can only be found by trial and error and should be noted for future burns.
2. To refuel, adjust air control to high, and give the fire time to brighten. Open the door slowly, this will prevent backpuffing.
3. Use wood of different shape, diameter and length (up to 457mm). Load your wood and try to place the logs so that the air can flow between them. Always use dry wood.
4. Do not load fuel to a height or in such a manner that would be hazardous when opening the door.
5. For extended or overnight burns, unsplit logs are preferred. Remember to char the wood completely on maximum setting before adjusting air control for overnight burn.

WARNING: Always keep loading door closed when burning. This heater is not designed for open door burning.

WARNING: No alteration or modification of the combustion air control assembly is permitted. Any tampering will void warranty and could be very hazardous.

WARNING: Do not use grates or andirons to elevate the fuel. Burn directly on the fire bricks. Replace broken or missing bricks. Failure to do so may create a hazardous condition.

Restarting After Extended or Overnight Burns

DO NOT OVERFIRE THIS HEATER:

Attempts to achieve heat output rates that exceed heater design specifications can result in permanent damage to the heater and chimney.

1. Open door and rake hot embers towards the front of the heater. Add a couple of dry, split logs on top of embers, close door.
2. Adjust air control to high (left position) and in just a few minutes, logs should begin burning.
3. After wood has charred, reset air control to desired setting.
4. To achieve maximum firing rate, set control to high (left position). Do not use this setting other than for starting or preheating fresh fuel loads.

Proper Draft

1. Draft is the force which moves air from the appliance up through the chimney. The amount of draft in your chimney depends on the length of the chimney, local geography, nearby obstructions and other factors.
2. Too much draft may cause excessive temperatures in the appliance. An uncontrollable burn or a glowing red stove part or chimney indicates excessive draft.
3. Inadequate draft may cause backpuffing into the room and plugging of the chimney. Smoke leaking into the room through appliance and chimney connector joints indicates inadequate draft.

Ash Removal

Whenever ashes get 76 mm to 102 mm inches deep in your firebox, and when fire has burned down and cooled, remove excess ashes. Leave an ash bed approximately (25 mm) deep on the firebox bottom to help maintain a hot charcoal bed.

CAUTION:

Ashes are to be removed only when the heater is cold.

Ash Cleanout System: The ash dump handle is located under the ash lip on the left hand side. To operate ash dump, pull handle out 13 mm and turn clockwise. This will unlock the ash dump and allow it to open. Hold handle open while pulling ashes into the opening. Avoid large embers as these still contain heat value. Release handle and push in to lock. Ensure ash dump door is properly engaged. Fill the cavity with the remaining ash level with the firebox floor. Pull out ashpan and discard ashes into metal container. Replace ashpan and ensure it is seated properly.

Disposal of Ashes

Do not burn with ash dump door open. Doing so will create a hazardous condition. Always leave about 25 mm of ash in firebox when cleaning.

Ashes should be placed in a metal container with a tight fitting lid. The closed container of ashes should be placed outside on a non-combustible floor or on the ground, well away from all combustible materials, pending final disposal. If the ashes are disposed of by burial in soil or otherwise locally dispersed, they should be retained in a closed container until all cinders have thoroughly cooled. Other waste should not be placed in this container.

Baffle Removal

Chimney connector pipe should be disconnected from stove to clean and inspect. Only if this is not possible should you remove baffle assembly.

DO NOT OPERATE WITH BAFFLE ASSEMBLY, TUBES OR INSULATION REMOVED.

Baffle Removal

1. Slide the Ceramic Baffle Board located above the tubes towards the front of the stove. Remove retaining pin at the back of the firebox, just under the baffle.
2. Lift the Baffle up to disconnect from the Baffle supply tube.
3. Move the Baffle to one side then tilt it sideways to drop down and remove from firebox. You may need to remove the opposite side brick rail to allow the Baffle to drop down. - To remove the Brick Rail, remove the brick directly under it then lift the rail up and inward to clear the locating pins
4. Inspect the gasket between baffle and supply tube. If necessary, replace with gasket (part#80000365) available from your Pacific Energy dealer.
5. Re-install baffle assembly in reverse order. The two side pieces of blanket insulation must be tight against the side rails. The Ceramic Board on top of the tubes must be pushed back tight against the Baffle.

Baffle Tube Removal

1. Slide the baffle board towards the front of the stove and drop it down and out the door opening. **Caution - Baffle Board material is very fragile.**
2. Pop out the retaining clip on the right side of the front baffle tube by rotating it up then disengage the tab from the hole in the front of the tube.
3. Slide the tube to the right to disengage the left end of the tube from the baffle air box and remove the tube from the unit.
4. Repeat steps 2 & 3 to remove the remaining tube.

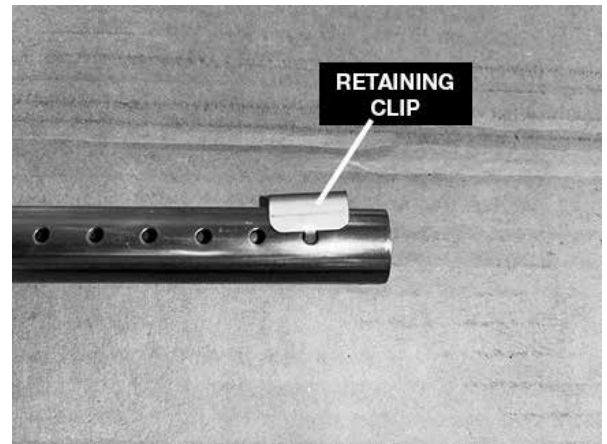

Installation

1. Install the baffle tubes first as per steps #3 & #4 below.
2. With the holes facing forward and the notch to the left side, insert the front baffle tube into the hole in the baffle air channel on the right at an angle and then raise and insert into the opposite hole on the left side baffle air assembly until the tube sits tight to the tab in the hole.
3. Place the retaining clip tab into the hole in the baffle tube on the right side and pop it back over the tube to secure it in place.
4. Insert the baffle board above the baffle tubes inside the firebox and under the retaining tabs on the baffle air channels. **Caution - Baffle Board material is very fragile.**
5. Slide the baffle board back until the lower edge is tight against the baffle.

Troubleshooting

Problem	Cause	Cure
Glass is Dirty	<ol style="list-style-type: none"> 1. Wood is wet 2. Turning down air control or damper too soon 3. Draft too low 4. Door gasket leakage 	<ul style="list-style-type: none"> • Use dry wood • Do not turn down until <ol style="list-style-type: none"> a) there is a good bed of coals b) the wood is charred • Improper chimney height and / or diameter, -consult dealer • Chimney plugged or restricted, - inspect and clean • Provide outside air for combustion • Replace gasket • Check latch for proper operation
Excessive Creosote Buildup	See 1,2,3, above.	See 1,2,3, above.
Low Heat Output	<ol style="list-style-type: none"> 1. Wood is wet 2. Fire too small 3. Draft too low 	<ul style="list-style-type: none"> • Use dry wood • Build a larger fire • Chimney plugged or restricted, - inspect and clean
Won't Burn Overnight	<ol style="list-style-type: none"> 1. Air control is set too high 2. Not enough wood 3. Draft too high 4. Poor quality or wet wood 	<ul style="list-style-type: none"> • Set air control lower • Unsplit wood is preferred for overnight burns • Excessive chimney height and/or diameter • Use good quality, dry wood
Wood Won't Burn	<ol style="list-style-type: none"> 1. Combustion air supply blocked 2. Draft too low 	<ul style="list-style-type: none"> • Check outside air supply for obstruction • Chimney plugged or restricted, -inspect and clean • Chimney oversized or otherwise unsuitable, -consult Dealer

Parts Diagram - VISTA LE2

ITEM	DESCRIPTION	PART NO.
1	Side shield, left or right.....	80002877
2	Door catch, Vista LE.....	80002387
3	Ashlip (c/w hardware).....	80000018
4	Air Control, Primary.....	80002215
5	Ash dump assembly.....	80001793
6	Ash drawer enclosure.....	80002388
7	Ash box (leg model).....	80002389
8	Ash Drawer Enclosure Cover.....	80002390
9	Pedestal.....	80002876
10	Ash box (pedestal model).....	80002392
11	Pedestal front cover assembly.....	80002393
12	Firebrick, NEO 1.6 LE2 / Vista LE2 (set).....	80002875
13	Glass(c/w Tape), NEO 1.6.....	80000220
14	Glass Retainer, NEO 1.6 / Vista LE.....	80002356
15	Gasket, Door, NEO 1.6/ Vista LE.....	80000156
16	Casting, Door, Vista LE, Black.....	80002502
 Casting, Door, Vista LE, Nickel.....	80002395
 Casting, Door, Vista LE, Brushed Nickel.....	80002396
17	Door handle assembly.....	80000660
18	Door Assembly, Met Black.....	11190026
 Door Assembly, Nickel.....	11190025
 Door Assembly, Brushed Nickel.....	11190024
19	Tube Air Box Gasket, NEO 1.6 LE/Vista LE.....	80002359
20	Tube Air Box (RHS)Hinge side, NEO 1.6 LE2/Vista LE2.....	80002891
21	Tube Air Box (LHS)Latch side, NEO 1.6 LE2/Vista LE2.....	80002892
22	Baffle Tubes, NEO 1.6 LE /Vista LE (set of 2).....	80002364
23	Baffle Board, NEO 1.6LE / Vista LE.....	80002357
24	Flame Shield, NEO 1.6 LE2 / Vista LE2,.....	80002878
25	Baffle, Pin, (10pc).....	80000364
26	Baffle, NEO 1.6 LE / Vista LE.....	80002361
27	Brick Rail Set, Left/Right, NEO 1.6 LE / Vista LE.....	80002363
28	Baffle Blanket (set), NEO 1.6 LE / Vista LE.....	80002362
29	Rear Brick Rail, NEO 1.6 LE2.....	80002879
30	Casting, Leg, Black.....	80000148
 Casting, Leg, Nickel.....	80000783
 Casting, Leg, Brushed Nickel.....	80000147
31	Legs, (4pc kit), Black.....	11130006
 Legs, (4pc kit), Nickel.....	11130007
 Legs, (4pc kit), Brushed Nickel.....	11130004
32	Baffle Gasket (not shown).....	80000365
33	Firebox Thermocouple.....	80002836
34	Optional Battery Box Assembly.....	11490005
35	Control Board Assembly.....	80002881
36	Motor Control Assembly.....	80002925
37	Flue Thermocouple.....	80002837
38	Flue Protector(Thermocouple Guard).....	80002832
39	Wall Adapter 12V.....	80002965
40	Baffle Tube Retaining Clip, LE2(not shown).....	80002889
41	Flue Gas Agitator.....	80002880

All parts may be ordered from your nearest Pacific Energy dealer. Contact Pacific Energy for the location of the dealer nearest you.

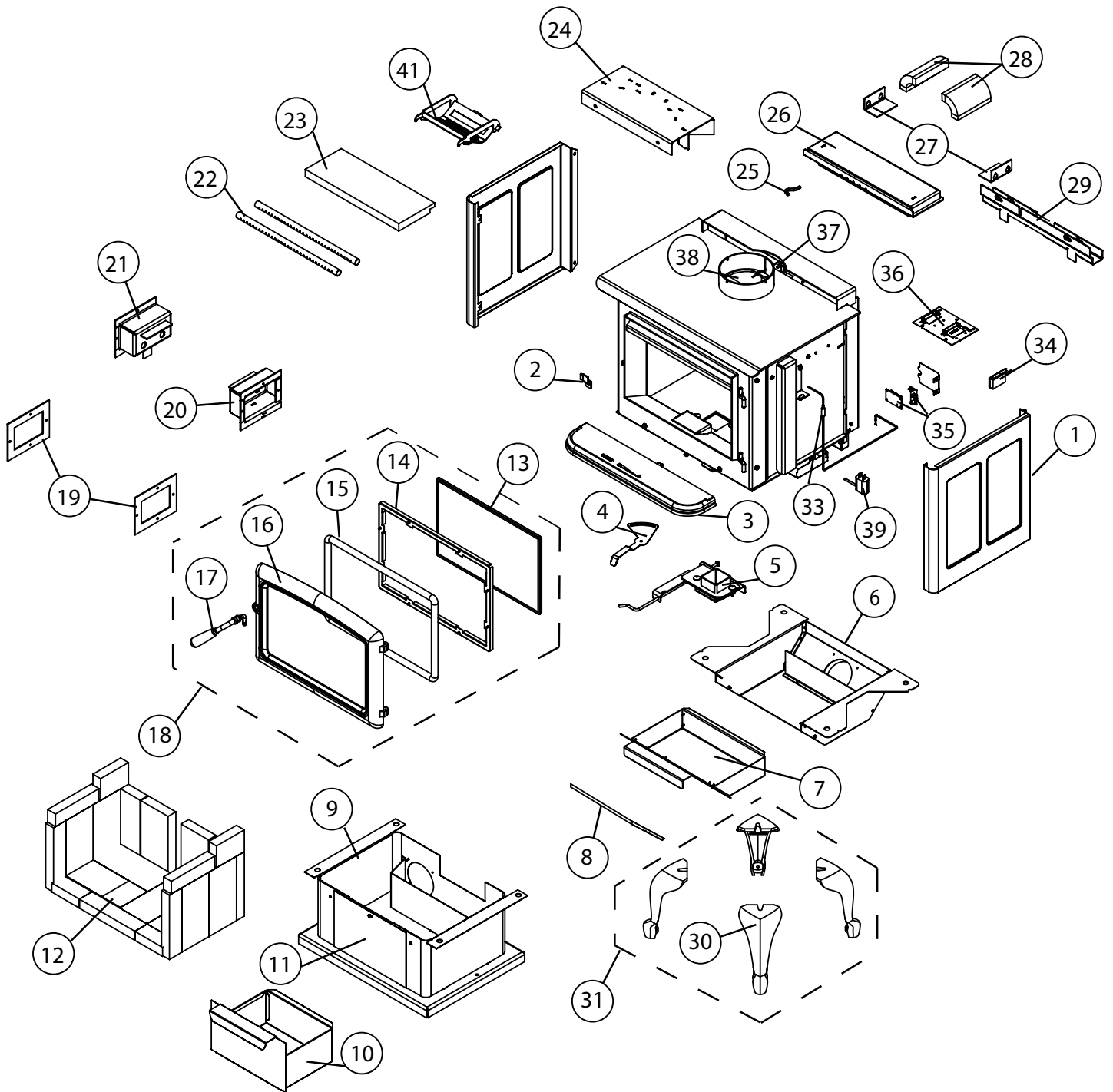

Figure 31. Replacement parts.

Compliance Plate



PACIFIC ENERGY FIREPLACE PRODUCTS LTD.
2975 ALLENBY RD., DUNCAN, BC V9L 6V8

Model: **VISTA LE2(M), ALDERLEA T4 LE2(M)**
Series: **A** Type: **FREESTANDING**

Tested by: **AUSTRALIAN SOLID FUEL TESTING**
3 GARDEN ST., MORWELL, VICTORIA
Test report no: **ASFT24113 16 DECEMBER 2024**

WHEN TESTED IN ACCORDANCE WITH:
AS/NZS 4012:2014 & AS/NZS4013:2014
MAXIMUM AVERAGE HEAT OUTPUT BURNING HARDWOOD
8.4 kW
OVERALL AVERAGE EFFICIENCY BURNING HARDWOOD
69%
PARTICULATE EMISSIONS FACTOR - 0.8g/kg
CATALYTIC COMBUSTOR - NO

ACMS KIT INSTALLED

Model: **VISTA LE2(ACMS), ALDERLEA T4 LE2(ACMS)**
Series: **A** Type: **FREESTANDING**

Tested by: **AUSTRALIAN SOLID FUEL TESTING**
3 GARDEN ST., MORWELL, VICTORIA
Test report no: **ASFT24119 17 DECEMBER 2024**

WHEN TESTED IN ACCORDANCE WITH:
AS/NZS 4012:2014 & AS/NZS4013:2014
MAXIMUM AVERAGE HEAT OUTPUT BURNING HARDWOOD
6.9 kW
OVERALL AVERAGE EFFICIENCY BURNING HARDWOOD
75%
PARTICULATE EMISSIONS FACTOR - 0.6g/kg
CATALYTIC COMBUSTOR - NO

Distributed by: PIVOT STOVES AND HEATING CO, 234-238 MOORABOOL STREET, GEELONG, VIC 3220, pivotstove.com.au

SERIAL #

MADE IN CANADA

DATE OF MANUFACTURE

210125

100007594





© 2025 Copyright Pacific Energy Fireplace Products LTD.

Reproduction, adaptation, or translation
without prior written permission is prohibited
except as allowed under the copyright laws.



For technical support, please contact your retailer

**Web site: www.pacificenergy.net
2975 Allenby Rd., Duncan, BC V9L 6V8**

Printed in Canada

