



BAY BX

Operating & Installation Instructions

AUSTRALIA

CONTENTS

QUICK GUIDE	4
OPERATING INSTRUCTIONS	5
FUEL	5
LIGHTING	5
CONTROLLING THE FIRE	5
REFUELLING	6
ASH CLEARANCE	6
REDUCED BURNING	6
MAINTENANCE	6
BAFFLE AND FLUE CLEANING	7
FLUE SWEEPING	7
TROUBLE SHOOTING	8
IF YOU NEED FURTHER HELP	9
INSTALLATION INSTRUCTIONS	10
UNPACKING THE STOVE	10
HEALTH AND SAFETY PRECAUTIONS	10
SPECIFICATION	10
FLUE	10
HEARTH AND FIRE SURROUND	10
CONNECTIONS TO FLUES	11
PRE LIGHTING CHECK	11
COMMISSIONING	11
STAND OPTIONS	11
TIS.129 FITTING THE CENTRE STAND	12
CLEARANCES	13
STANDARD HEARTH DIMENSIONS	14
FLUE CLEARANCES DIAGRAM	15
STANDARD DEFAULT TRIPLE SKIN FLUE KIT	16
INSULATED ROOM SEAL FLUE KIT	17
INSULATED ROOM SEAL FLUE KIT	18
COMPLIANCE DATA	19
BAY BX DIMENSIONS	20
BAY BX PARTS LIST	21
CHARNWOOD AUSTRALIA 10 YEAR GUARANTEE	22

QUICK GUIDE

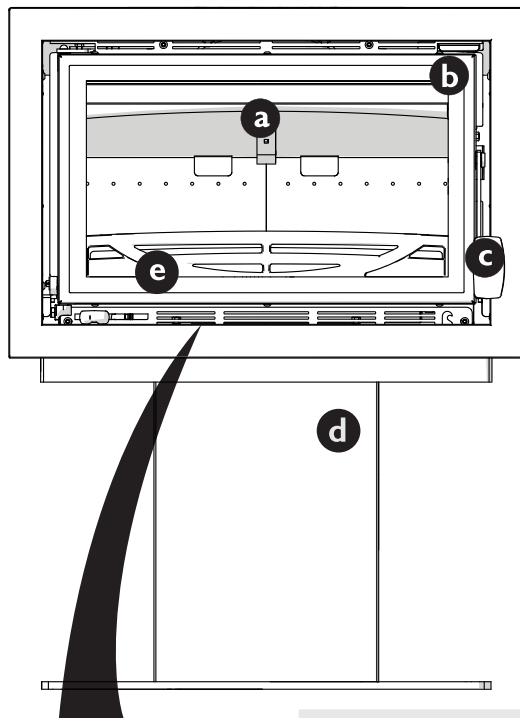

- A Baffle**
Improves efficiency of stove by slowing down flue gases
- B Door**
Keep closed when stove is in use
- C Door handle**
Pull to open
- D Optional stand**
Three options available:
Centre Stand, Store Stand & Bench Stand
- E Fuel retainer**
Ensure fuel does not protrude beyond retainer

Air Control

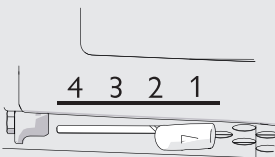

1. Slumber
2. Medium output
3. High output
4. Boost

MAINTENANCE AND CLEANING

GLASS

Wipe with damp, lint free cloth. Any stubborn deposits on the glass may be removed with a proprietary stove glass cleaner or ceramic hob cleaner.

BAFFLE PLATE

Take down once a month and clean. Sweep sooty deposits into fire

FLUE

Have flue swept annually. Flue can be swept through stove.

SERVICING

Stove should be serviced by a professional at least once a year.

LIGHTING AND CONTROLLING THE FIRE

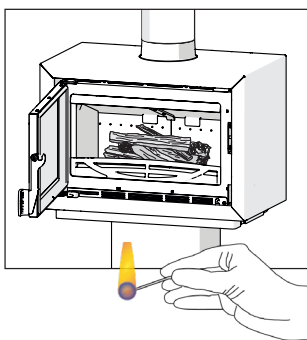

Add kindling and paper or firelighters. Set the air control to boost and close door.

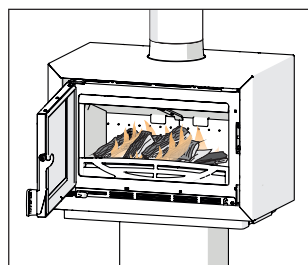

Once kindling is alight, add smaller logs. Keep air control set to boost and close door.

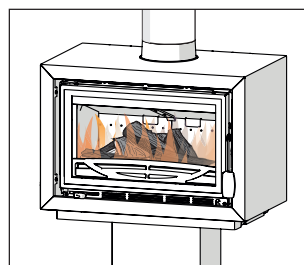

Add larger logs once fire is established. The Air control can be reduced to medium output.

Suitable fuels for your

Charwood:
Wood logs

Unsuitable fuels:

Petroleum coke
Liquid fuel
Household waste
Coal singles
Small nuts or coal dust
Wet or unseasoned wood
Smokeless mineral fuel



Congratulations on becoming the owner of a Charnwood Bay BX Stove. Your stove has been approved to burn wood logs if it is used in accordance with these instructions. It is very important that you read and understand these instructions before using the stove.

Before lighting the stove check with the installer that the work and checks described in the Installation Instructions have been carried out correctly and that the flue has been swept, is sound and free from any obstructions. The stove is not suitable for use in a shared flue system.

This stove will not produce significant smoke if well seasoned logs of less than 20% moisture content are burnt and these instructions are adhered to. Burning wet (>20% moisture content) wood and operating the stove in an irresponsible manner may produce smoke which is illegal in smoke controlled areas.

Remember that the stove will be hot and that it is made from hard materials – ensure that you have good balance before operating the fire. Always use the provided operating tool and gloves.

Do not use an aerosol spray on or near the stove when it is alight. There is a risk of explosion or flash ignition of the spray.

When using the stove in situations where children, aged and/or infirm persons are present a fireguard must be used to prevent accidental contact with the stove.

The stove is suitable for intermittent operation.

FUEL

This stove has been designated to burn wood. Only dry well seasoned wood should be burnt on this appliance as burning wet unseasoned wood will give rise to heavy tar deposits in the stove, on the glass and within the flue. Burning wet unseasoned wood will also result in considerably reduced outputs. The wood should be cut and split and then left to season in a well ventilated dry place for at least one year but preferably two years before use.

Approximate suitable log sizes are:

480mm (19in) long and 75mm (3in) diameter

Log moisture content of less than 20% is recommended.

PETROLEUM COKE IS NOT SUITABLE FOR USE ON THIS APPLIANCE. ITS USE WILL INVALIDATE THE GUARANTEE.

This stove is not designed to burn household waste.

LIGHTING

On initial lighting, the stove may smoke and give off an odour as the silicon paint with which the firebox is painted reacts to the heat. This is normal and will cease after a short time, but meanwhile the room should be kept well ventilated.

At first only light a small fire and burn it slowly for two hours to allow any residual moisture in the flue to evaporate.

Light the stove using dry kindling wood and paper or fire lighters. Put the paper, or fire lighters, and kindling in the firebox and cover with a few small dry logs. Set the air control to boost (see Fig. 1) Light the paper or fire lighters. The door may be left cracked open for a few minutes to assist the combustion and heat up the firebox more quickly. When the kindling wood is well alight add a few more small logs, close the door but leave the air control fully open. When the flames are established around these logs, load the stove with the required fuel load. Maintain the air control at maximum at this stage. Once the fire is up to temperature the airwash system will begin to work, so allow the fire to become hot before adjusting the air control to the required setting. During the lighting period, do not leave the stove unattended. Do not leave the door open except as directed above to avoid excessive smoke.

When relighting the stove, leave the ash on the base, unless it is becoming too deep, in which case some of it may be removed.

CONTROLLING THE FIRE

The rate of burning and hence the output is controlled by the air control (see Fig.1)

Open the air control fully (boost position) when lighting or when rapid burning is required. It should not be left fully open for long periods as this can cause over-firing or excessive smoke production. For high output move the air control to the 'High Output' position' or for low burning to the fully closed position.

When the fire is burning normally the air control gives enough airwash to keep the glass clean. However, it will not always be possible to keep the glass clean with the air control fully closed. For correct firing we recommend the use of a stove pipe thermometer which may be purchased from your supplier or from Charnwood.



Fig. 1 Stove controls

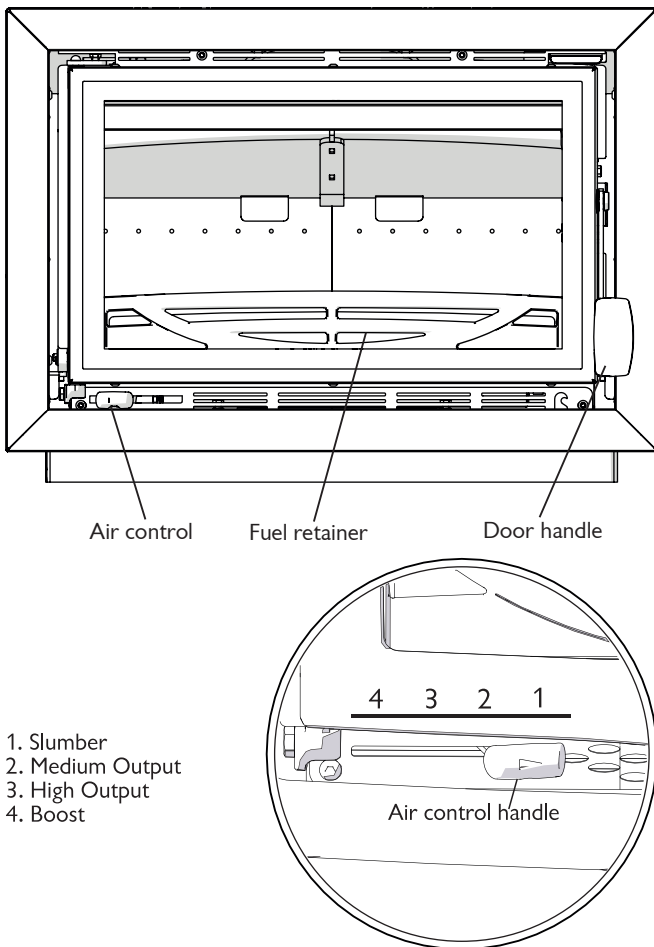

- 1. Slumber
- 2. Medium Output
- 3. High Output
- 4. Boost

REFUELLING

Keep the firebox well filled but do not allow fuel to spill over the top of the fuel retainer.

Logs should be evenly distributed, filling the firebed to give the most pleasing flame pattern. The air control must be fully opened after refuelling until the flames are established above the fire. It is best to refuel on to a hot bed of embers. If at this point the fire starts to die, the door must be cracked open until the fire is revived. If the fire has started to die down before refuelling, then more kindling wood must be added, the air control opened fully and the door cracked open to re-establish the firebed before adding larger logs (see suitable log sizes in Fuel section). This will avoid excessive smoke emission.

Care should be taken, especially when burning wood, that fuel does not project over the fuel retainer or damage to the glass may be caused when the door is closed. It can also cause the glass to blacken up. Maximum filling height is such that logs cannot fall from the fire when the door is opened and does not come above the level of the

air holes in back bricks.

Do not operate with the door open except as directed by the instructions as this can cause excessive smoke.

ASH CLEARANCE

For optimum wood burning, it is important to leave a layer of ash, around 1cm thick, on the base of the stove. If the ash is becoming too deep, clear the top layer of ash cleared using the scoop provided.

Fig.2 Ash Scoop

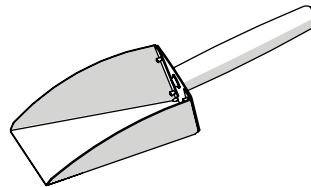

REDUCED BURNING

For reduced burning the fire door must be closed.

When burning wood in areas that are not smoke controlled, load some large logs on the fire and allow to burn for half an hour before closing the air control (this will help to reduce tar deposits in the flue). Some experimentation may be necessary to find the setting most suitable for the type of fuel being used and the draw on the flue.

MAINTENANCE

Cleaning

The stove is finished with a high temperature paint which will withstand the temperatures encountered in normal use. This may be cleaned with a damp lint-free cloth when the stove is cold. Should re-painting become necessary, high temperature paints are available from your supplier or from stove shops.

Cleaning the Glass

Most deposits on the glass may be burnt off simply by running the fire at a fast rate for a few minutes. If it becomes necessary to clean the glass then open the door and allow it to cool. Clean the glass using a damp cloth and then wiping over with a dry cloth. Any stubborn deposits on the glass may be removed with a proprietary stove glass cleaner or ceramic hob cleaner. Do not use abrasive cleaners or pads as these can scratch the surface which will weaken the glass and cause premature failure



When Not in Use

If the fire is going to be out of use for a long period (for instance in the summer) then to prevent condensation, and hence corrosion, the air control should be left fully open and the fire door left ajar. It is also advisable to sweep the flue and clean out the fire. Spraying the inside of the door with a light oil, such as WD40, will also help to keep all internal parts working well. After long periods where the fire has been out of use, the flue and appliance flue should be cleaned before lighting.

Door Seals

For the fire to operate correctly it is important that the door seals are in good condition. Check that they do not become worn or frayed and replace them when necessary.

Servicing

It is recommended that the fire is serviced once a year to keep it in first class working order. After cleaning out the firebox thoroughly, check that all internal parts are in good working order, replacing any parts that are beginning to show signs of wear. Check that the door seals are in good condition and that the doors seal correctly. A servicing guide is available on request. Repairs or modifications may only be carried out by the Manufacturer or their approved agents. Use only genuine Charnwood replacement parts.

BAFFLE AND FLUE CLEANING

It is important that the baffle plate and all the stove flues are kept clean in order to prevent potentially dangerous fume emission. Check by looking up into the firebox for signs of soot or fly-ash on the baffle plate and sides of the firebox. If there are signs of a build up of soot or fly-ash then cleaning is necessary. Cleaning should occur at

least once a month and more frequently if required. Let the fire out and ensure it is cold before carrying out these operations. If necessary, wear your Charnwood gloves to prevent irritation from soot deposits.

The baffle plate consists of two firebrick panels which rest on the central bracket and the two side bricks. To lower, push the brick up towards the topmost corner of the stove, and lower down diagonally (see Fig. 3). Any sooty deposits should then be swept from the plate and into the fire.

Return the baffle plates to their correct position by reversing the above method, ensuring they slot onto the bracket and rest securely on the side panels.

Fig.3 Baffle Location

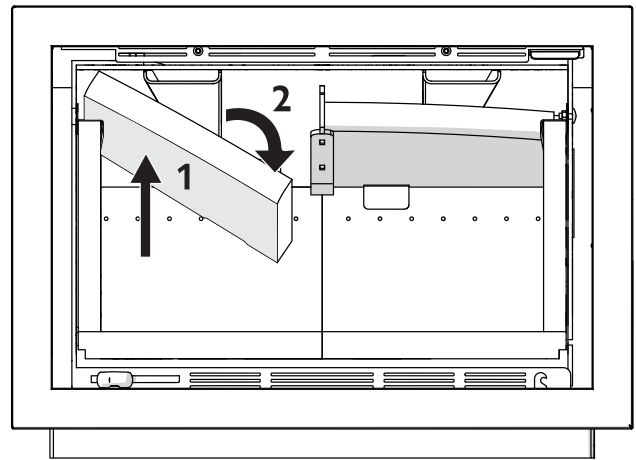

Lowering the baffle plate

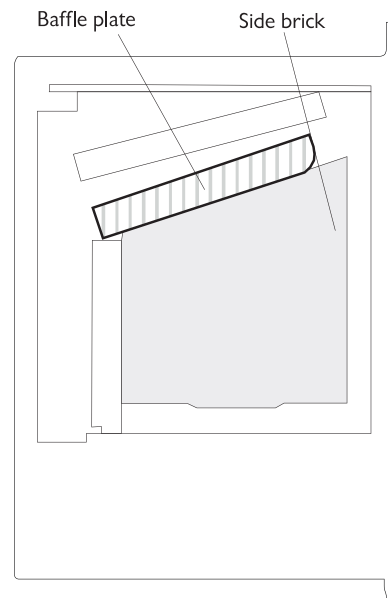

Side View

FLUE SWEEPING

When installing your Charnwood into an existing brick flue that has previously served as an open fire, it is possible that the higher flue gas temperature from a stove may loosen soot deposits with the consequent risk of flue blockage. It is therefore recommended that the flue be swept a second time within a month of regular use after installation.

Your Charnwood flue should be swept at least twice a year. It will generally be possible to sweep the flue through the appliance.

First remove the baffle plate. Then sweep the flue ensuring that soot is removed from all horizontal surfaces after sweeping.



In situations where it is not possible to sweep through the appliance the installer will have provided alternative means, such as a flue access door.

After clearing any soot from within the stove, replace the baffle (see Fig. 3).

It is important to use the correct flue brush for the flue size, different types of sweep's brushes are available to suit different flue.

For prefabricated insulated flues the manufacturers instructions with regard to sweeping should be consulted.

TROUBLE SHOOTING

Fire Will Not Burn

Check that:

- a) the air inlet is not obstructed in any way,
- b) flues and flue are clear,
- c) a suitable fuel is being used,
- d) there is an adequate air supply into the room,
- e) If an extractor fan is fitted, that it is not causing lack of flue draft when operating.
- f) there is sufficient draw in the flue. Once the flue is warm a draught reading of at least 1.25 mm (0.05 in.) water gauge (12Pa) should be obtained.

Blackening of Door Glass

Differences in flue draughts mean that the best settings of the air controls will vary for different installations. A certain amount of experimentation may be required, however the following points should be noted and with a little care should enable the glass to be kept clean in most situations:

- a) Wet or unseasoned wood, or logs overhanging the front fence will cause the glass to blacken.
- b) The airwash relies on a supply of heated air to keep the glass clean, therefore, when lighting the stove allow the firebed to become well established before closing the air control. This may also be necessary when re-fuelling the stove.
- c) When re-fuelling keep the fuel as far back from the front fence as possible, do not try to fit too much fuel into the firebox
- d) Do not completely close the air control.

It is always more difficult to keep the glass clean when running the

stove very slowly for long periods.

If blackening of the glass still occurs check that all flue connections and the blanking plate are well sealed. It is also important that the flue draw is sufficient and that it is not affected by down-draught. When the flue is warm a draught reading of at least 1.25 mm (0.05 in.) water gauge (12Pa) should be obtained. Some blackening of the glass may occur below the level of the fuel retainer. This will not obscure the view of the fire or affect its performance.

Fume Emission

Warning Note: Properly installed and operated this appliance will not emit fumes. Occasional fumes from de-ashing and re-fuelling may occur. Persistent fume emission is potentially dangerous and must not be tolerated. If fume emission does persist, then the following immediate actions should be taken:

- a) **Open doors and windows to ventilate the room and then leave the premises.**
- b) **Let the fire out and safely dispose of the fuel from the appliance.**
- c) **Check for flue or flue blockage, and clean if required.**
- d) **Do not attempt to re-light the fire until cause of fuming has been identified, if necessary seek professional advice.**

The most common cause of fume emission is a flue blockage. For your own safety the flue must be kept clean

Fire blazing out of control

Check that:

- a) The door is tightly closed.
- b) The air control slider is fully closed.
- c) A suitable fuel is being used.
- d) Door seals and air slide are intact.

Flue Fires

If the flue is thoroughly and regularly swept, flue fires should not occur. However, if a flue fire does occur close the air control, and tightly close the door of the appliance. This should cause the flue fire to go out in which case the controls should be kept closed until the stove has gone out. The flue should then be cleaned. If the flue fire does not go out when the above action is taken then the fire brigade should be called immediately. After a flue fire the chimney should be carefully examined for any damage. Expert advice should be sought if necessary



IF YOU NEED FURTHER HELP

If you need further help with your Charnwood then your Installer will be able to provide the answers to most questions. Your Local Charnwood Dealer has a great deal of experience and will also be able to provide helpful advice. Further help is available from Pivot Stove & Heating who will be pleased to give advice, if necessary.



UNPACKING THE STOVE

The stove arrives bolted and strapped to its pallet. There must be adequate facilities for unloading and manoeuvring into position. The wrapping is first removed, then the stove released from the pallet by removing 4 pallet bolts using a 10mm spanner. The pallet brackets can now be removed from the stove by tilting it and using a 13mm spanner to remove the bolts. The bolts should be refitted and used for levelling the stove. The pallet is intended to be cut up and used for kindling fuel.

HEALTH AND SAFETY PRECAUTIONS

Please take care when installing the stove.

Ideally there should not be an extractor fan fitted in the same room as the appliance. If this situation is unavoidable then specialist advice should be taken to ensure that the extractor fan does not cause the appliance to emit fumes into the room. The external air kit will help with this in some situations. Alternatively, an additional air supply correctly positioned may be necessary. It is essential to carry out a spillage test to ensure that the appliance can operate safely when the extractor fan is operating.

There must be an adequate air supply into the room in which the appliance is installed to provide combustion air. The combustion air supply must be via a permanently open vent. The requirement for minimum free area is partly dependent on the design air permeability of the house. In older properties the air permeability will be above $5.0\text{m}^3/(\text{h}\cdot\text{m}^2)$, but in some modern properties it may be less. The vent must be positioned such that it is not liable to blockage. Minimum areas are given in the following table:

AIR PERMEABILITY $\text{m}^3/(\text{h}\cdot\text{m}^2)$	MINIMUM VENT AREA $\text{cm}^2(\text{in}^2)$
	BAY BX
>5.0	not required
<5.0	27.5 (4.3)

A fixed ducted air supply may be used as an alternative to the traditional method of using a permanent open vent into a room to supply air for combustion.

External air supply kits are available please contact Charnwood for more information. Instruction sheet ref: TIS 120

The ducted air kit is connected to the 100mm spigot on the underside

of the stove. If the stove is installed directly on a hearth, without any additional stands, the ducted air supply will need to be set into the floor with appropriate protection.

It is recommended that a carbon monoxide alarm is installed in the same room as the appliance, in accordance with the alarm manufacturer's instructions.

SPECIFICATION

SPECIFICATION	BAY BX
Fuel	Wood logs
Maximum average heat output burning hardwood:	4kW
Overall average efficiency burning hardwood:	68%
Particulate emissions factor:	0.8g/kg

FLUE

In order for the appliance to perform satisfactorily the flue must give sufficient draw when warm (minimum of 12pa/0.05" wg). The height of the flue must comply with local building regulation requirements. The internal dimensions of the flue **MUST NOT BE LESS THAN 150mm (6")**.

The listed flue's construction and installation must comply with the requirements of AS/NZS2918:2018 and must also meet local building codes. The flue must be suitable for burning solid fuel, lined in good condition and at least 4.6m in height from the base of the appliance. The flue and all its component's must be installed according to the manufacturer's instructions. The flue exit requirements of AS/NZS2918:2018 are 1000mm above the roof and 600mm above any projection within 3000mm, see flue clearances diagram (page 16). This stove is not suitable for use in a shared flue system.

It is important that there is sufficient draw in the flue and that the flue does not suffer from down-draught. When the flue is warm the draw should be not less than 1.25mm (0.05") water gauge (12 Pa). If in doubt about the chimney seek expert advice.

HEARTH AND FIRE SURROUND

The stove must stand on a fireproof hearth and must not be situated closer than the minimum distance from combustible materials to the sides or rear above hearth level unless adequately fireproofed



in accordance with local building regulations. If installed on a combustible floor, floor protection must be provided in the form of a non-combustible material to the minimum specifications described in the 'minimum distances to combustibles' section (pages 13 - 15) When the fire door is open, it extends beyond the flat front of the stove by 436mm.

If in doubt as to the positioning of the stove, expert advice should be sought either from the supplier or the local building inspector. The fireplace must allow good circulation of air around the appliance to ensure that maximum heat is transferred to the room and also to prevent the fireplace from overheating. A gap of 150mm (6") each side and 300mm (12") above the appliance should give sufficient air circulation. If a wooden mantelpiece or beam is used in the fireplace it should be a minimum of 460mm (18"), and preferably 600mm (24") from the appliance. In some situations it may be necessary to shield the beam or mantelpiece to protect it.

The appliance should be installed on a floor with adequate load-bearing capacity. If an existing construction does not meet this requirement then please take suitable measures to achieve this. (e.g. load distributing plate.)

CONNECTIONS TO FLUES

The Bay BX must be connected to the flue using flue pipe of 150mm (6") diameter : and is tested for both Air Cooled triple Skin Flue Kits & Room Seal Insulated flue Kits that have been tested to AS/NZS2918:2018

Horizontal lengths of flue must be kept to a minimum and should not be more in length than the flue diameter.

PRE LIGHTING CHECK

Ensure that the baffle and upper baffle is fitted in the roof of the appliance. For location and positioning see Fig. 3.

Check that the front fence is fitted correctly and that the door closes properly.

COMMISSIONING

On completion of the installation allow a suitable period of time for the fire cement and mortar to dry out before lighting the fire. Make a layer of ash or sand on the base of the stove before lighting. Check to ensure that smoke and fumes are taken from the appliance up the flue and emitted safely. Also check all joints and seals. On completion of the installation and commissioning please leave the operating

instructions with the customer and advise them on the use of the appliance.

STAND OPTIONS

The Bay BX is available with 3 stand options; store stand, bench stand and centre stand.

When placing the Bay BX on any of the stand options the outer casing should sit on the Table Top Plinth (part number JT035). The table top plinth is provided as standard with all Bay BX models.

In the case of the centre stand (part number JT034) the bolts that would have been used as levelling feet in the bottom of the plinth are used to attach the stand to the stove. Instructions on how to fit the centre stand are provided in sheet TIS129 on page 12



Fitting the Bay 5 BX centre stand

Do not attempt to fit the centre stand alone. The correct manual handling principles must be adhered to at all times.

Preparing the stove

1. Carefully remove the door by taking the weight of the door and lifting the upper hinge pin until the door comes free and can be lifted off. Remove and save the upper and lower hinge pins including the small brass washer on the bottom hinge.

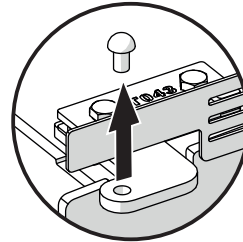

Top hinge

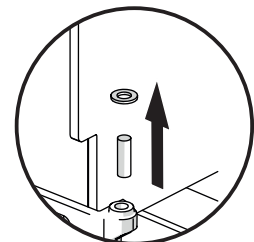

Lower hinge

2. Remove any loose parts inside the firebox, including the throat plate bricks and hanger.

3. Carefully lower the stove onto its back. Using a 13mm socket, undo the 4 M8 bolts on the bottom of the stove to remove the table top plinth (part no JT035)

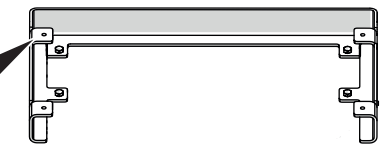
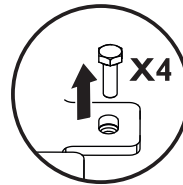

Remove table top plinth from stove base

Preparing the centre stand

4. Remove all packaging from the centre stand and undo the 4 wood screws securing the stand to pallet.

5. Carefully lower the stand onto its back and remove the 4 M8 bolts that secure the pallet brackets to the stand.

6. Lift the stand in an upright position and screw in the 4 M8 grub screws and conceal by pushing in the 4 plastic caps.

Conceal with:
4 X grub screws
4 X plastic caps

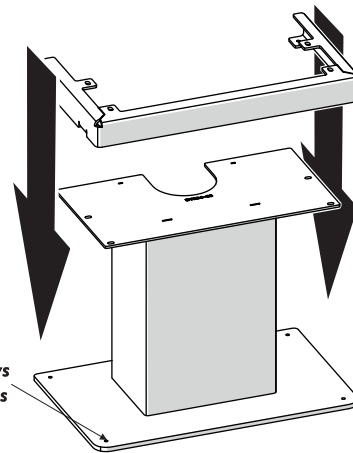

Slide table top plinth over the centre stand

7. Slide the table top plinth (JT035) over the top of the stand ensuring that the 4 slotted holes on the plinth are aligned with the 4 slotted holes on the stand.

Fitting the stove to the stand

Carefully lift the stove and lower it centrally onto the stand ensuring that the 4 M8 hank nuts in the base of the stove are in line with the slotted holes on the plinth and stand. Once positioned secure into place using the 4 X M8 bolts and washers that were previously used to attach the plinth to the stove. Tighten the bolts using 13mm socket.

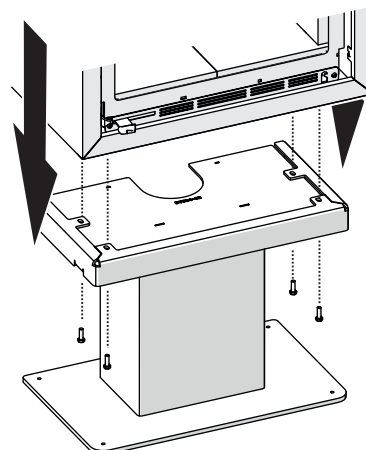

Lower stove centrally onto stand

Reattach the door by following step 1



PARALLEL POSITION

CORNER POSITION

COMBUSTIBLE WALLS

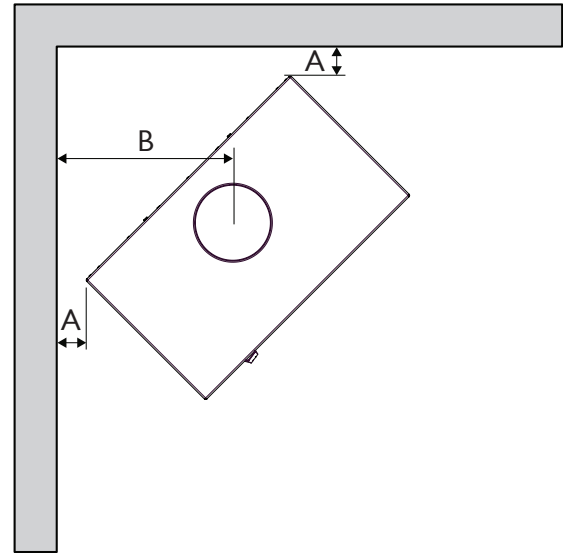
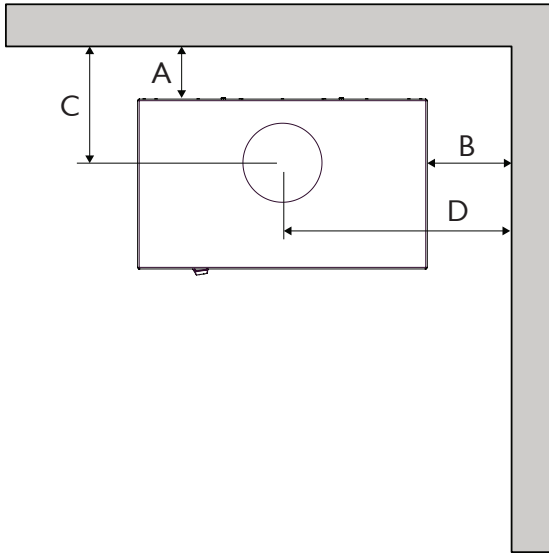

BAY BX

Standard Clearance

A	125mm
B	200mm
C	276mm
D	544mm

Corner Clearance

A	70mm
B	418mm

Note: The safe distance to combustibles figures quoted here were achieved using a **Room Seal Flue Kit**.

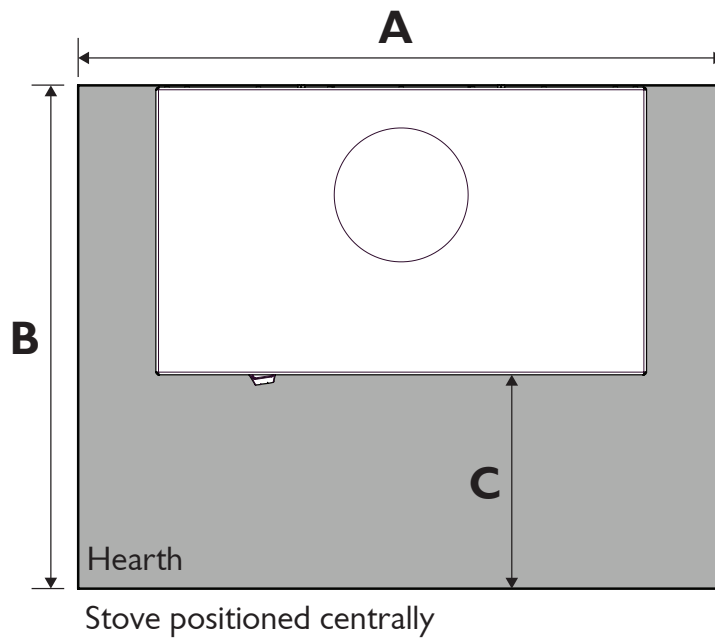

BAY BX

MIN. DIMENSIONS DEFAULT HEARTH

A	905mm
B	705mm
C	300mm

NON-COMBUSTIBLE MATERIAL

Minimum thickness: 6mm

Minimum thermal resistivity: $0.026\text{m}^2\text{K}/\text{W}$

Installed in accordance with AS/NZS 2918:2018 3.3.2

FLUE CLEARANCES DIAGRAM



Summary of minimum height of flue system exit requirements from AS/NZS 2918:2018

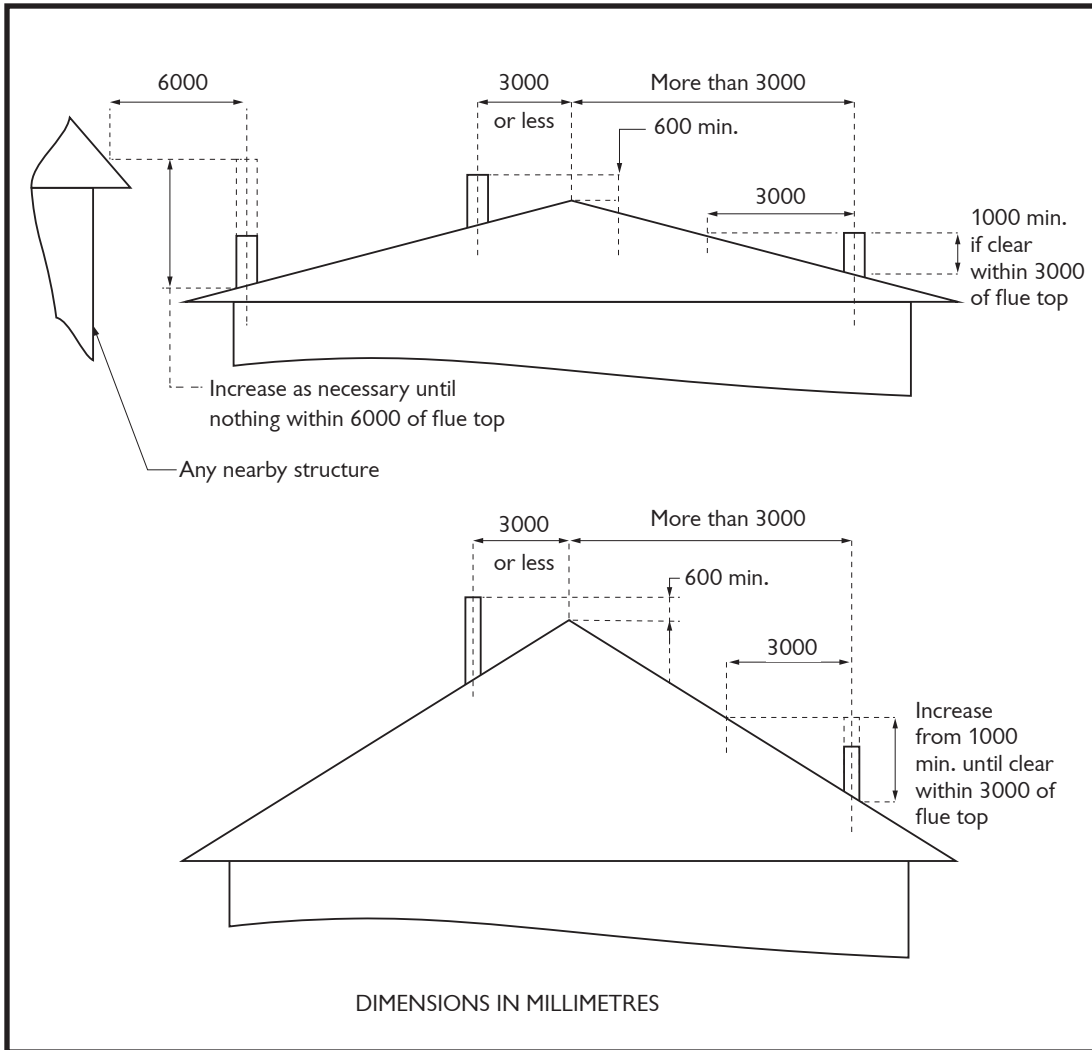

STANDARD DEFAULT TRIPLE SKIN FLUE KIT

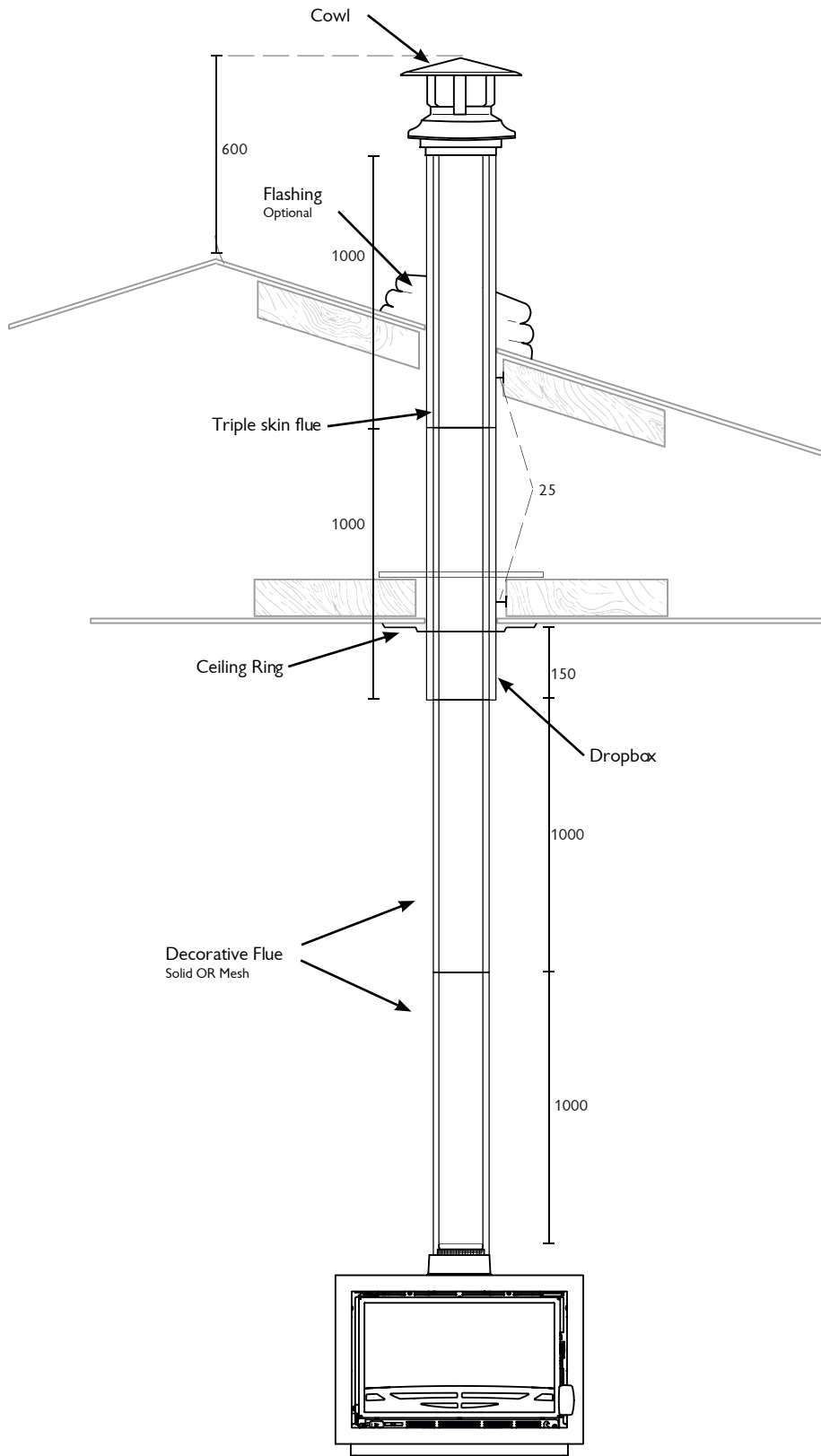

INSULATED ROOM SEAL FLUE KIT



STANDARD FLUE KIT

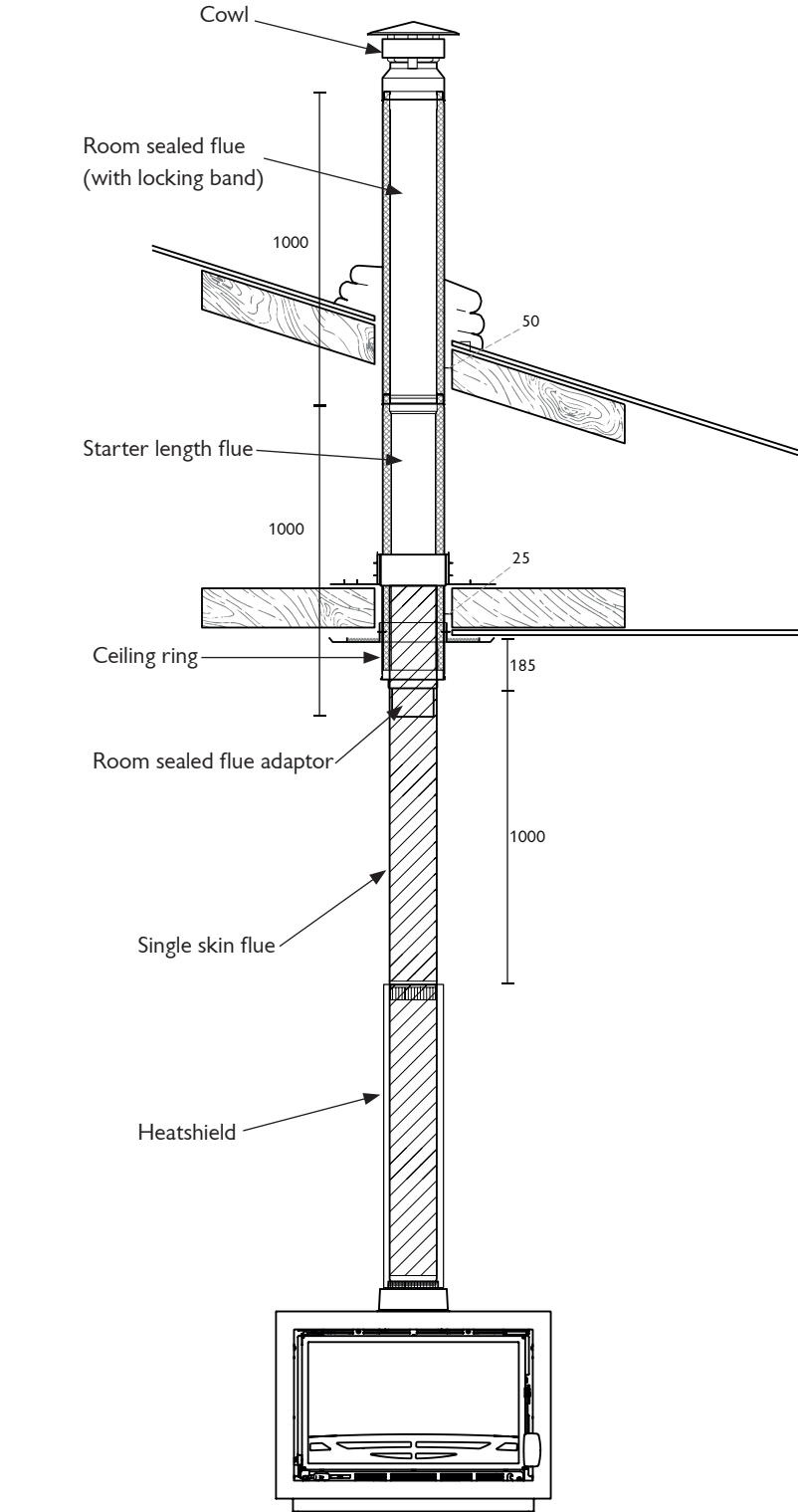

INSULATED ROOM SEAL FLUE KIT



FULLY SEALED FLUE KIT

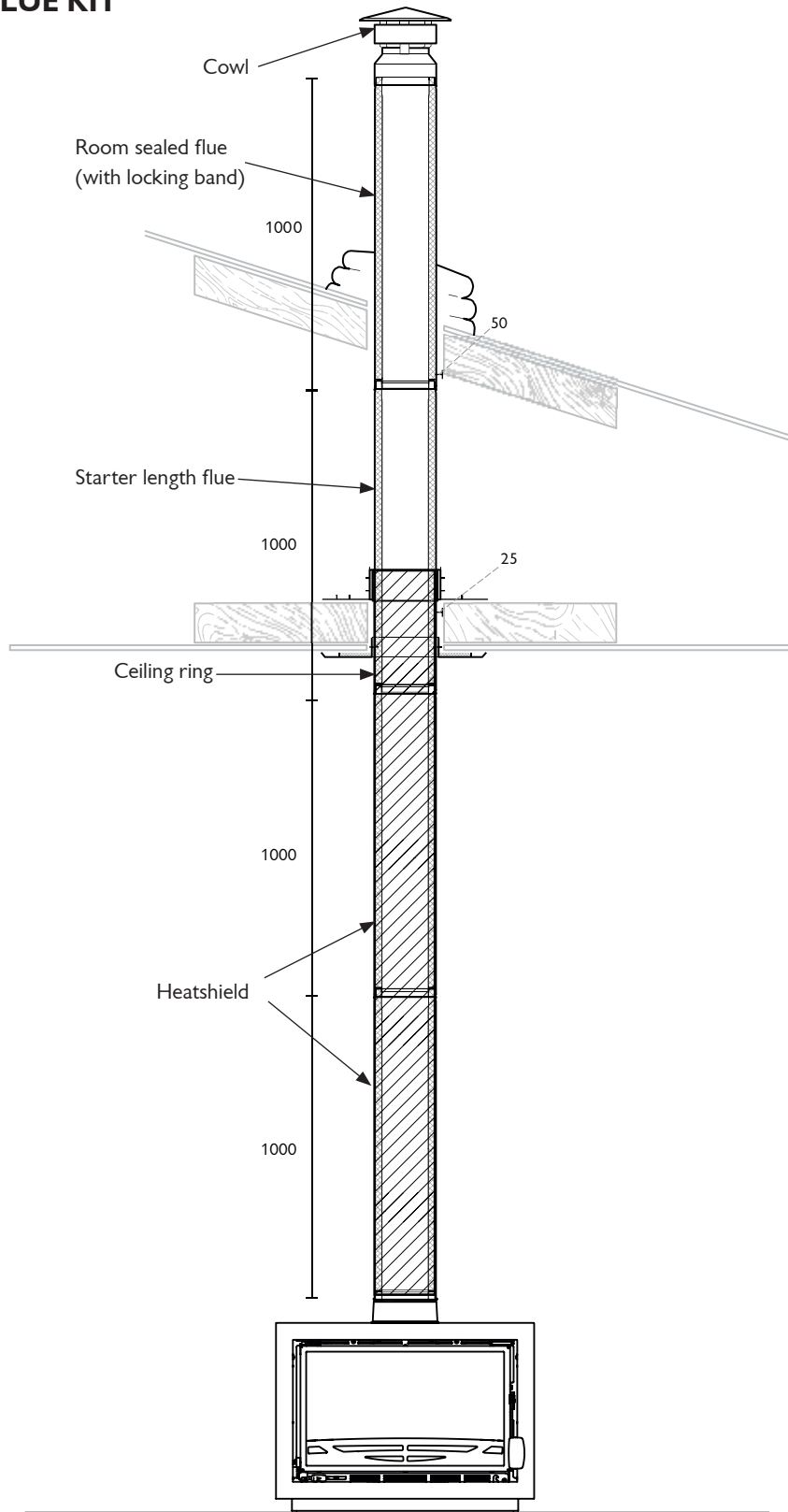

COMPLIANCE DATA



BAY BX - COMPLIANCE DATA



CHARNWOOD
NEWPORT, IW
PO30 5WS, UK
WWW.CHARNWOOD.COM

DISTRIBUTED BY:
PIVOT STOVE & HEATING CO
120 VICTORIA ST,
NORTH GEELONG VIC 3215,
AUSTRALIA

ONLY USE RECOMMENDED FUELS.

This wood heater needs periodic inspection and repair for proper operation. Consult the operating & installation manual for minimum clearance distances from combustibles. No catalytic combustor. Follow the users instructions.

TESTED BY:	ASFT
TEST REPORT NO:	ASFT20114-1
TESTED TO:	AS/NZS 4012/4013 (2014)
DATE:	24/11/2020

MODEL:	Bay BX
MODEL CODE:	JTA
TYPE:	Freestanding

MAXIMUM AVERAGE HEAT OUTPUT BURNING HARDWOOD:	4kW
OVERALL AVERAGE EFFICIENCY BURNING HARDWOOD:	68%
PARTICULATE EMISSIONS FACTOR:	0.8g/kg

Compliance plate riveted onto rear panel

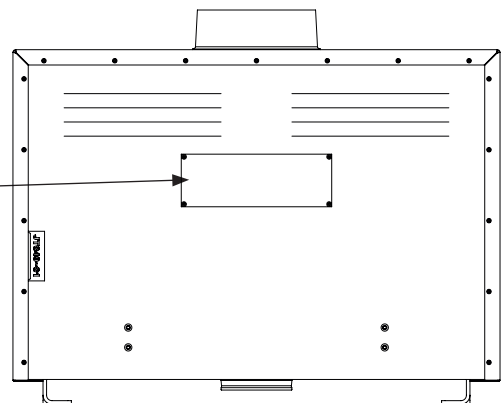

BAY BX DIMENSIONS

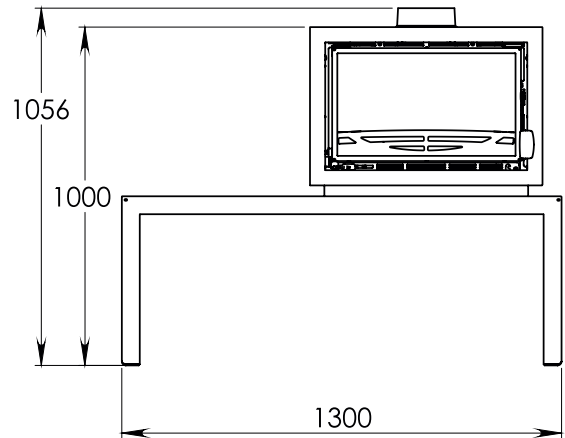
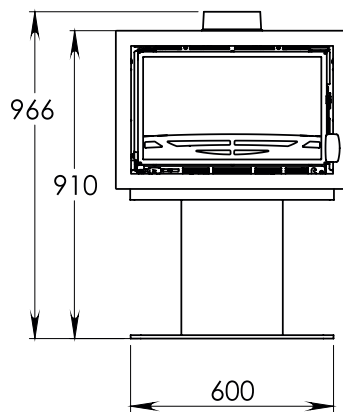
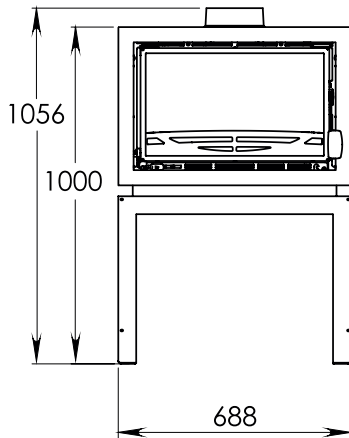
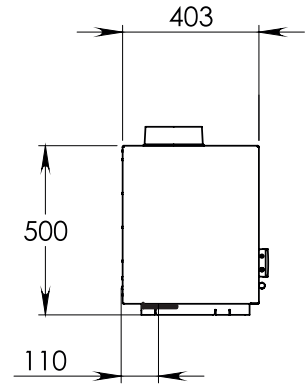
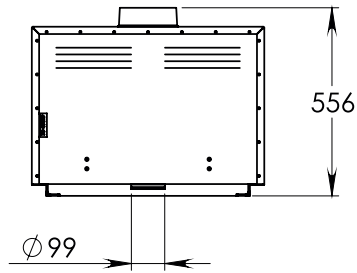
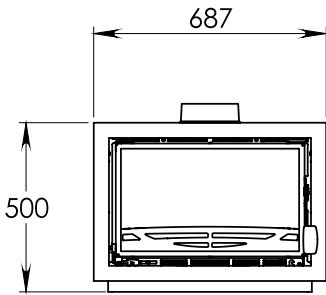
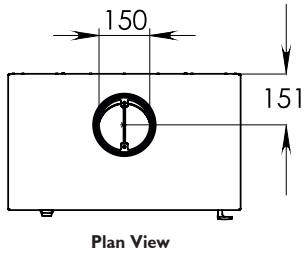

Side view

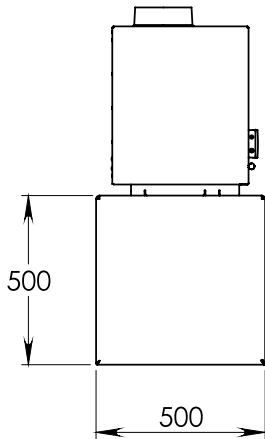

Store Stand

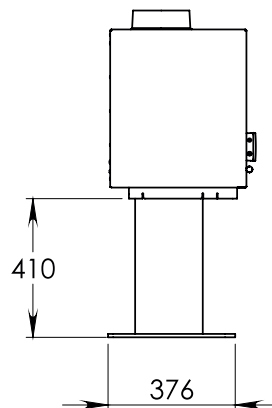

Centre Stand

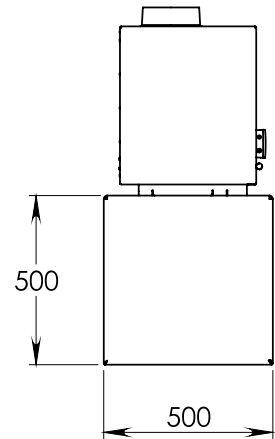

Bench Stand

Charnwood Bay BX Australia Parts List



Issue A

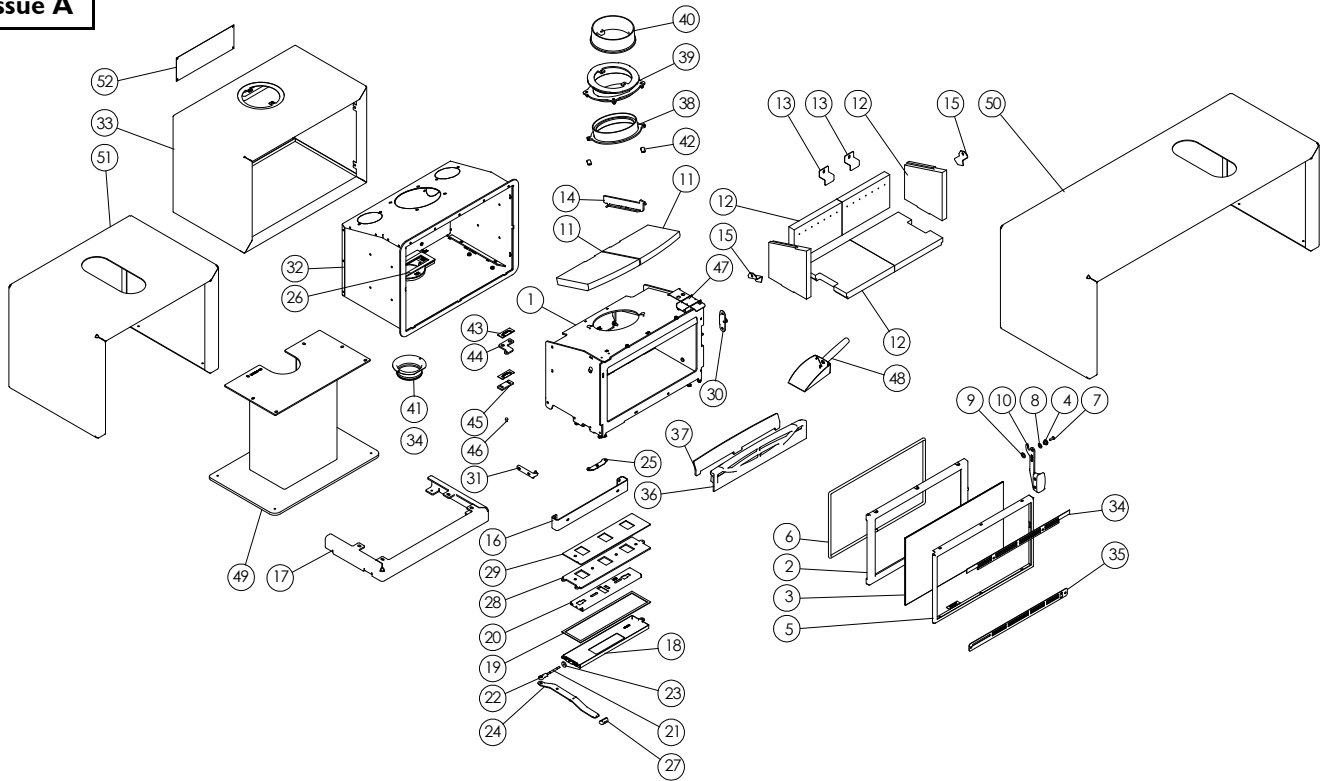

Item	Part No.	Description	Item	Part No.	Description
1	001/XR010	Firebox	27	008/XR012	Control Knob
2	002/BT001	Door Casting	28	004/XR072	Air Control Plate
3	006/BT018	Glass	29	008/XR073	Air Control Gasket
4	008/MR047	Handle Pivot Boss	30	004/MR044	Latch Plate
5#	004/BT023	Glass Trim	31	002/XR020	Lower Hinge Bracket
6	008/XR076	Door Seal	32	010/XR011	Convection Casing
7	008/FFS046	M6x20 CSK Allen Screw	33#	005/JT049	Outer Casing
8	008/FFW027	M10 Wavy Washer	34	004/JT025	Screen Top
9	008/FFW007	M10x19 Washer	35	004/JT029	Screen Lower
10	010/MR038	Handle Assembly	36	002/MR017	Fence
11	011/MR0315	Set of Baffle Firebricks	37	010/MR078	Ash Barrier
12	011/XR0305	Set Base, Back & Side Bricks	38	010/XR098	6" Lower Flue Adaptor
13	004/XR008	Back Brick Bracket	39	010/JT096	6" Upper Flue Adaptor
14	010/XR087	Throat Plate Support Bracket	40#	002/CH12B	Flue Collar
15	004/XR025	Side Brick Bracket	41	010/MR126	100mm Spigot Assy
16	004/JT052	Rear Fixing Bracket	42	004/GR090	Fastener Retainer
17	010/JT035	Table Top Plinth	43	010/BT043	Upper Hinge Spacer
18	004/XR055	Air Slide Cover	44	010/XR041	Upper Hinge Bracket
19	008/XR063	Air Box Upper Gasket	45	010/XR042	Hinge Spacer
20	004/XR007	Air Control Slider	46	008/FFR016	Hinge Pin
21	004/XR064	Control Rod	47	012/JTA011	Serial No Label
22	008/FFM056	Rod End	48	010/XR088	Ash Scoop
23	008/BR052	Felt Washer	49#	010/JT034	Centre Stand
24	010/XR022	Air Slide Control Handle	50#	010/JT070	Bench Stand
25	004/XR058	Clicker Assembly	51#	010/JT071	Store Stand
26	008/XR062	Airbox Lower Gasket	52	012/JTA180	Compliance Plate

*These items are not shown on the drawing.

Please specify colour when ordering.

To obtain spare parts please contact your local stockist giving Model, Part No. and Description. In case of difficulty contact the manufacturer at the address shown. This drawing is for identification purposes only.

CHARNWOOD AUSTRALIA 10 YEAR GUARANTEE



To register your 10 Year Stove Guarantee please visit or scan QR:

www.charnwood.com/my-stove/guarantees/

and enter the following code: CGG-AUS

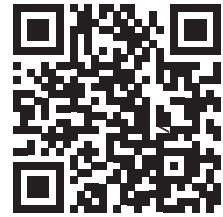

TERMS AND CONDITIONS

10 Year Warranty: The firebox of your Charnwood Stove is guaranteed against material and manufacturing defect for a period of 10 years

1 Year Warranty: The consumable items such as bricks, rope seal and associated parts are guaranteed for a period of 1 year.

- The guarantee registration form must be completed online and submitted within 14 days of purchase to enable the guarantee to be activated.
- The following conditions apply:
- If any part fails due to manufacturing or material defect within the guarantee period Charnwood will, free of charge, either repair or replace the part at their discretion. The decision of Charnwood is final.
- This guarantee is for parts only.
- Charnwood will not be liable for any consequential loss or incidental loss, damage or injury however caused.
- This guarantee will become void if the appliance: is not installed in accordance with the installation instructions; is not regularly serviced in accordance with the installation instructions; is subject to misuse or neglect, including the use of non-recommended fuel; or if repairs or modifications have been carried out by anyone other than Charnwood or their official representatives.
- All claims on this guarantee must be made through the supplier of the appliance and must be accompanied by proof of purchase.
- Nothing in this guarantee shall affect your statutory rights.

EXCLUSIONS AND LIMITATIONS

This Guarantee does not cover the following:

- Charnwood will not be liable for any consequential loss or incidental loss, damage or injury however caused.
- This guarantee will become void if the appliance is not installed by a suitably qualified and is not installed in accordance with the AS.NZS 2918
- This guarantee will become void if the appliance is not installed in accordance with the installation instructions and is not regularly serviced, in accordance with the installation instructions.
- If the product is subject to misuse or neglect, including the use of non-recommended fuels.
- If repairs or modifications have been carried out by anyone other than Charnwood or their authorised representatives.
- Damage caused by over-firing of the stove. Please refer to our operating instructions for further details.
- Damage caused by storing or using the product in a damp environment. Corrosion caused by condensation, damp or water ingress into the flue, chimney or the surrounding of the stove.
- Defects or faults caused by local conditions such as draught problems and chimney defects.
- The paint finish will require touching up or repainting from time to time. Maintaining the finish is normal practice and is not covered by the guarantee.

your premier dealer

charnwood BISHOPS WAY, NEWPORT, ISLE OF WIGHT PO30 5WS, UNITED KINGDOM
TEL. +44 (0) 1983 537777 • FAX. +44 (0) 1983 537788 • WWW.CHARNWOOD.COM

A Division of A.J. Wells & Sons Limited Registered in England No. 03809371