



arc7

Operating & Installation Instructions

AUSTRALIA

CONTENTS

QUICK GUIDE	4
OPERATING INSTRUCTIONS	5
FUEL	5
LIGHTING	5
CONTROLLING THE FIRE	5
WOOD ASH REMOVAL GRATE	6
RIDDLING	6
REFUELLING	6
ASH CLEARANCE	7
OPERATING TOOL HOLDER	7
REDUCED BURNING	7
MAINTENANCE	7
BAFFLE AND FLUE CLEANING	8
FLUE SWEEPING	8
TROUBLE SHOOTING	8
IF YOU NEED FURTHER HELP	9
INSTALLATION INSTRUCTIONS	10
UNPACKING THE STOVE	10
HEALTH AND SAFETY PRECAUTIONS	10
SPECIFICATION	10
FLUE	10
HEARTH AND FIRE SURROUND	10
CONNECTIONS TO FLUES	11
PRE LIGHTING CHECK	11
COMMISSIONING	11
COOKING PLATE	11
CLEARANCES	12
CLEARANCES WITH REAR FLUE ADAPTOR	13
HEARTH DIMENSIONS	14
FLUE CLEARANCES DIAGRAM	15
STANDARD DEFAULT TRIPLE SKIN FLUE KIT	16
INSULATED ROOM SEAL FLUE KIT	17
INSULATED ROOM SEAL FLUE KIT	18
INSULATED ROOM SEAL FLUE KIT	19
COMPLIANCE DATA	20
ARC 7 DIMENSIONS	21
ARC 7 STORE STAND PARTS LIST	22
ARC 7 LOW STAND PARTS LIST	23
ARC 7 OPTIONAL DRAWER PARTS LIST	24
CHARNWOOD AUSTRALIA 10 YEAR GUARANTEE	25

QUICK GUIDE

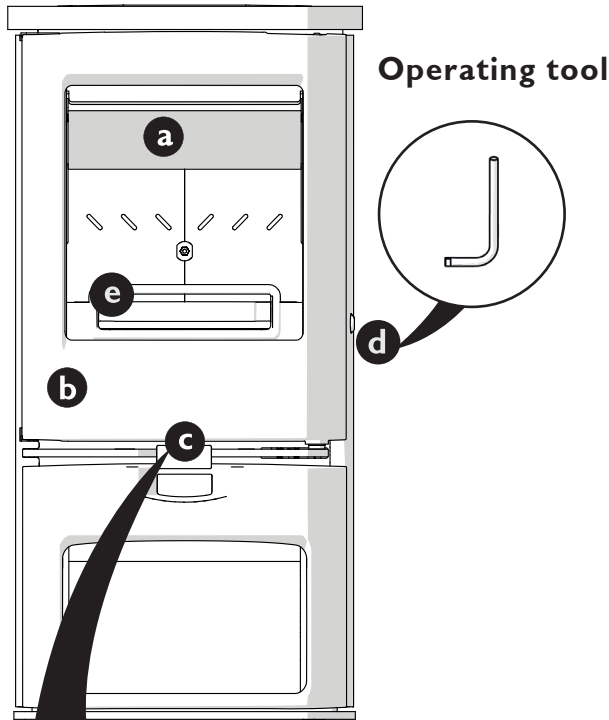

- A Baffle**
Improves efficiency of stove by slowing down flue gases
- B Door**
Keep closed when stove is in use
- C Door handle**
Pull to open
- D Riddler knob**
Use operating tool to riddle
- E Fuel retainer**
Ensure fuel does not protrude beyond retainer

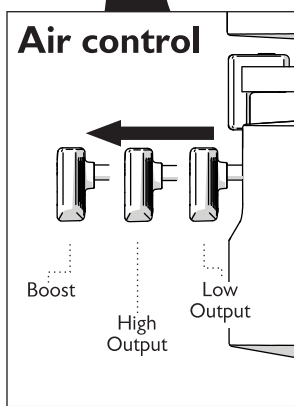

MAINTENANCE AND CLEANING

- GLASS** Wipe with damp, lint free cloth. Any stubborn deposits on the glass may be removed with a proprietary stove glass cleaner or ceramic hob cleaner.
- BAFFLE PLATE** Take down once a month and clean. Sweep sooty deposits into fire
- FLUE** Have flue swept annually. Flue can be swept through stove.
- SERVICING** Stove should be serviced by a professional at least once a year.

LIGHTING AND CONTROLLING THE FIRE

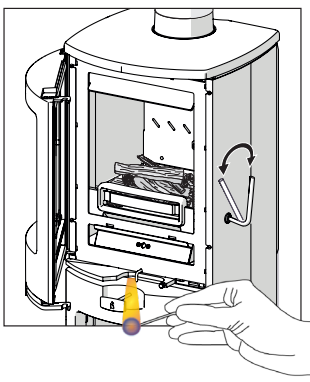

Add kindling and paper or firelighters. Keep air control fully out and door cracked open.

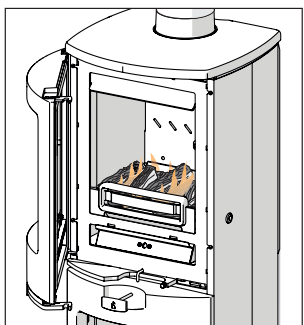

Once kindling is alight, add smaller logs. Keep air control fully out and close door.

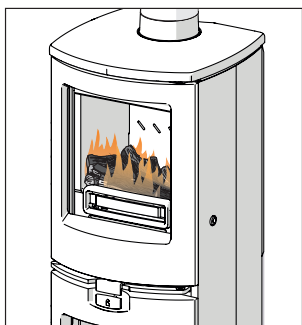

Add larger logs once fire is established. Air control can be reduced to minimum.

Suitable fuels for your
Charnwood:
Wood logs

Unsuitable fuels:
Petroleum coke
Liquid fuel
Household waste
Coal singles
Small nuts or coal dust
Wet or unseasoned wood
Smokeless mineral fuel



Congratulations on becoming the owner of a Charnwood Arc Stove. Your stove has been approved to burn wood logs if it is used in accordance with these instructions. It is very important that you read and understand these instructions before using the stove.

Before lighting the stove check with the installer that the work and checks described in the Installation Instructions have been carried out correctly and that the flue has been swept, is sound and free from any obstructions. The stove is not suitable for use in a shared flue system.

This stove will not produce significant smoke if well seasoned logs of less than 20% moisture content are burnt and these instructions are adhered to. Burning wet (>20% moisture content) wood and operating the stove in an irresponsible manner may produce smoke which is illegal in smoke controlled areas.

Remember that the stove will be hot and that it is made from hard materials – ensure that you have good balance before operating the fire. Always use the provided operating tool and gloves.

Do not use an aerosol spray on or near the stove when it is alight. There is a risk of explosion or flash ignition of the spray.

When using the stove in situations where children, aged and/or infirm persons are present a fireguard must be used to prevent accidental contact with the stove.

The stove is suitable for intermittent operation.

FUEL

This stove has been designated to burn wood. Only dry well seasoned wood should be burnt on this appliance as burning wet unseasoned wood will give rise to heavy tar deposits in the stove, on the glass and within the flue. Burning wet unseasoned wood will also result in considerably reduced outputs. The wood should be cut and split and then left to season in a well ventilated dry place for at least one year but preferably two years before use.

Approximate suitable log sizes are:

180mm(7in) long and 75mm (3in) diameter

Log moisture content of less than 20% is recommended.

PETROLEUM COKE IS NOT SUITABLE FOR USE ON THIS APPLIANCE. ITS USE WILL INVALIDATE THE GUARANTEE.

This stove is not designed to burn household waste.

LIGHTING

On initial lighting, the stove may smoke and give off an odour as the silicon paint with which the firebox is painted reacts to the heat. This is normal and will cease after a short time, but meanwhile the room should be kept well ventilated.

At first only light a small fire and burn it slowly for two hours to allow any residual moisture in the flue to evaporate.

Light the stove using dry kindling wood and paper or fire lighters. Put the paper, or fire lighters, and kindling in the firebox and cover with a few small dry logs. Open the air control fully (see Fig. 1) Light the paper or fire lighters. The door may be left cracked open for a few minutes to assist the combustion and heat up the firebox more quickly. When the kindling wood is well alight add a few more small logs, close the door but leave the air control fully open. When the flames are established around these logs, load the stove with the required fuel load. Maintain the air control at maximum at this stage. Once the fire is up to temperature the airwash system will begin to work, so allow the fire to become hot before adjusting the air control to the required setting. During the lighting period, do not leave the stove unattended. Do not leave the door open except as directed above to avoid excessive smoke.

When relighting the stove, leave the ash on the base, unless it is becoming too deep, in which case some of it may be removed.

CONTROLLING THE FIRE

The rate of burning and hence the output is controlled by the air control (see Fig.1)

Open the air control fully (boost position) when lighting or when rapid burning is required. It should not be left fully open for long periods as this can cause over-firing or excessive smoke production. For high output move the air control to the 'click position' or for low burning to the fully closed position.

When the fire is burning normally the air control gives enough airwash to keep the glass clean. However, it will not always be possible to keep the glass clean with the air control fully closed. For correct firing we recommend the use of a stove pipe thermometer which may be purchased from your supplier or from Charnwood.

The Charnwood Arc 7 is fitted with an air control stop. This stops the stove from burning too slowly.



Fig. 1 Stove controls

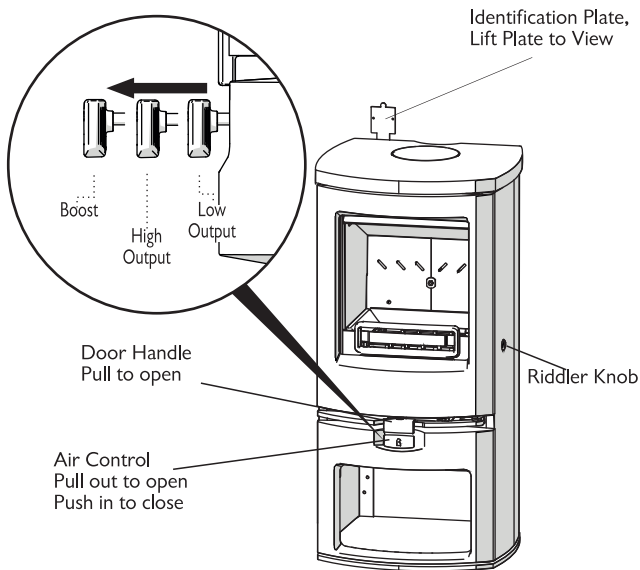

WOOD ASH REMOVAL GRATE

Your Charnwood Arc fitted with a wood ash removal grate to enable wood to be burned and ash to be cleared. The grate has two positions:

- 1) In the open position the grate bars are vertical with gaps in between allowing the primary combustion air to come up through the grate and through the fuel bed.
- 2) In the closed position the grate bars are horizontal, allowing the combustion air to come round the sides of the grate and over the top of it. When in the closed position ash is able to build up on the grate as is necessary for effective wood burning.

Movement of the grate from one position to the other is effected using the operation tool supplied as shown in Fig.3.

The grate is put into the open position by turning the operation tool clockwise. The grate is put into the closed position by turning the operation tool anticlockwise. When burning wood ensure that the lever is pushed in (Fig.2) To riddle the appliance the tool should be moved between the clockwise and anticlockwise positions several times. When burning wood the ash should be allowed to build up and riddling should only be carried out once or twice a week.

Fig 2. Operating the wood ash removal grate

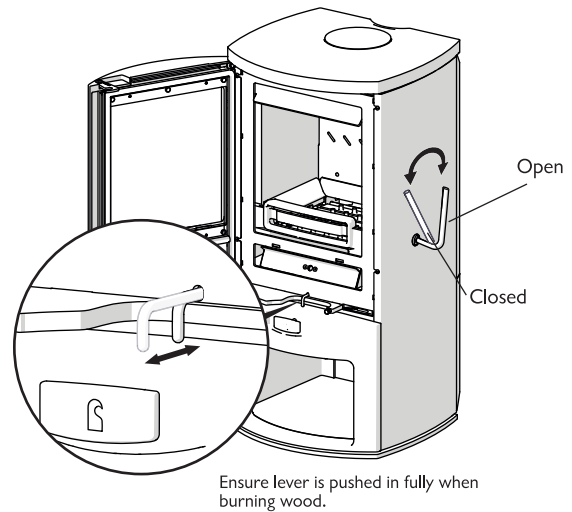

RIDDLING

When burning wood, ash should be allowed to build up and only riddled when the ash begins to cover the rear fireplate. The fire should be riddled with the door shut (see Fig.2). Place the operating tool onto the riddling lever and rotate between the open and closed positions several times. Too much riddling can result in emptying unburnt fuel into the ashpan and should therefore be avoided. After riddling, the grate should be put back into the closed position for burning wood.

Fig 3. Riddling tool

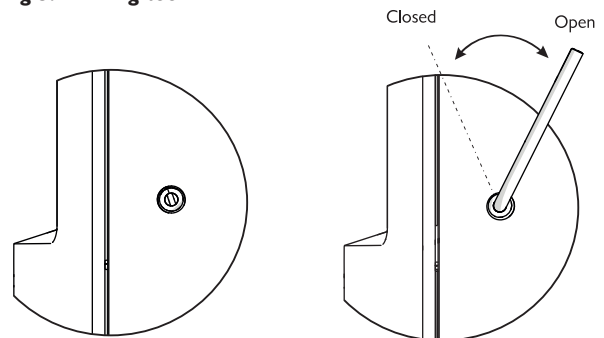

REFUELLING

Keep the firebox well filled but do not allow fuel to spill over the top of the fuel retainer.

Logs should be evenly distributed, filling the firebed to give the most pleasing flame pattern. The air control must be fully opened after refuelling until the flames are established above the fire. It is best to refuel on to a hot bed of embers. If at this point the fire starts to die, the door must be cracked open until the fire is revived. If the fire has



started to die down before refuelling, then more kindling wood must be added, the air control opened fully and the door cracked open to re-establish the firebed before adding larger logs (see suitable log sizes in Fuel section). This will avoid excessive smoke emission.

Care should be taken, especially when burning wood, that fuel does not project over the fuel retainer or damage to the glass may be caused when the door is closed. It can also cause the glass to blacken up. Maximum filling height is such that logs cannot fall from the fire when the door is opened and does not come above the level of the air holes in back bricks.

Do not operate with the door open except as directed by the instructions as this can cause excessive smoke.

ASH CLEARANCE

Before removing ash ensure that it has cooled down. The ashpan slides out for easy ash removal.

To make ash removal easier there are ash carriers available. These may be purchased from your supplier or, in case of difficulty, from Charnwood.

Fig.4 Ashpan

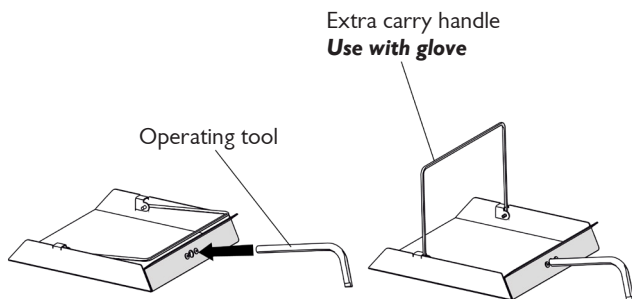

OPERATING TOOL HOLDER

When not in use the operating tool can be stored upright inside the store stand. (See fig. 5.)

Fig. 5. Operating tool storage

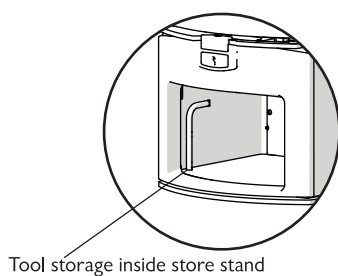

REDUCED BURNING

For reduced burning the fire door must be closed.

When burning wood in areas that are not smoke controlled, load some large logs on the fire and allow to burn for half an hour before closing the air control (this will help to reduce tar deposits in the flue). Some experimentation may be necessary to find the setting most suitable for the type of fuel being used and the draw on the flue.

MAINTENANCE

Cleaning

The stove is finished with a high temperature paint which will withstand the temperatures encountered in normal use. This may be cleaned with a damp lint-free cloth when the stove is cold. Should re-painting become necessary, high temperature paints are available from your supplier or from stove shops.

Cleaning the Glass

Most deposits on the glass may be burnt off simply by running the fire at a fast rate for a few minutes. If it becomes necessary to clean the glass then open the door and allow it to cool. Clean the glass using a damp cloth and then wiping over with a dry cloth. Any stubborn deposits on the glass may be removed with a proprietary stove glass cleaner or ceramic hob cleaner. Do not use abrasive cleaners or pads as these can scratch the surface which will weaken the glass and cause premature failure

When Not in Use

If the fire is going to be out of use for a long period (for instance in the summer) then to prevent condensation, and hence corrosion, the air control should be left fully open and the fire door left ajar. It is also advisable to sweep the flue and clean out the fire. Spraying the inside of the door with a light oil, such as WD40, will also help to keep all internal parts working well. After long periods where the fire has been out of use, the flue and appliance flue should be cleaned before lighting.

Door Seals

For the fire to operate correctly it is important that the door seals are in good condition. Check that they do not become worn or frayed and replace them when necessary.

Servicing

It is recommended that the fire is serviced once a year to keep it in first class working order. After cleaning out the firebox thoroughly, check that all internal parts are in good working order, replacing



any parts that are beginning to show signs of wear. Check that the door seals are in good condition and that the doors seal correctly. A servicing guide is available on request. Repairs or modifications may only be carried out by the Manufacturer or their approved agents. Use only genuine Charnwood replacement parts.

BAFFLE AND FLUE CLEANING

It is important that the upper and lower baffles and all the stove flueways are kept clean in order to prevent potentially dangerous fume emission. They should be cleaned at least monthly, and more frequently if necessary. It is necessary to let the fire out to carry out these operations.

To remove the lower baffle brick, slide it forwards so that it clears the back brick, then slide it either right or left so that the opposite side clears the top of the side brick and can be gently lowered. The upper baffle can then be located and rests on top of the air wash tubes (fig.6). Any sooty deposits should then be swept from both plates and into the fire.

First return the upper baffle to its location above the air wash tubes. To return the lower baffle brick to its correct position- At an angle, insert the baffle brick so that it sits on top of either the right or left side brick. Raise the opposite side and slide so that the baffle brick is central and supported by both side bricks. Slide back so that the baffle brick rests neatly on the top of the back bricks.

Fig.6 Baffle Location

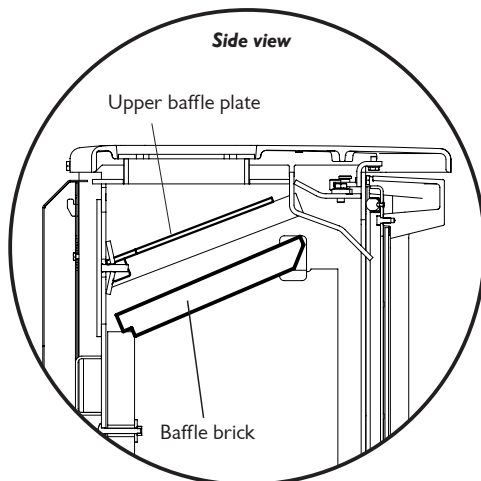

FLUE SWEEPING

When installing your Charnwood into an existing brick flue that has previously served as an open fire, it is possible that the higher flue gas temperature from a stove may loosen soot deposits with the

consequent risk of flue blockage. It is therefore recommended that the flue be swept a second time within a month of regular use after installation.

Your Charnwood flue should be swept at least twice a year. Where the top outlet or vertical rear flue connector is used it will generally be possible to sweep the flue through the appliance.

First remove the upper and lower baffles. Then sweep the flue ensuring that soot is removed from all horizontal surfaces after sweeping.

In situations where it is not possible to sweep through the appliance the installer will have provided alternative means, such as a flue access door.

After clearing any soot from within the stove, replace the baffle (see Fig. 6).

It is important to use the correct flue brush for the flue size, different types of sweep's brushes are available to suit different flue.

For prefabricated insulated flues the manufacturers instructions with regard to sweeping should be consulted.

TROUBLE SHOOTING

Fire Will Not Burn

Check that:

- the air inlet is not obstructed in any way,
- flues and flue are clear,
- a suitable fuel is being used,
- there is an adequate air supply into the room,
- If an extractor fan is fitted, that it is not causing lack of flue draft when operating.
- there is sufficient draw in the flue. Once the flue is warm a draught reading of at least 1.25 mm (0.05 in.) water gauge (12Pa) should be obtained.

Blackening of Door Glass

Differences in flue draughts mean that the best settings of the air controls will vary for different installations. A certain amount of experimentation may be required, however the following points should be noted and with a little care should enable the glass to be kept clean in most situations:



- a) Wet or unseasoned wood, or logs overhanging the front fence will cause the glass to blacken.
- b) The airwash relies on a supply of heated air to keep the glass clean, therefore, when lighting the stove allow the firebed to become well established before closing the air control. This may also be necessary when re-fuelling the stove.
- c) When re-fuelling keep the fuel as far back from the front fence as possible, do not try to fit too much fuel into the firebox
- d) Do not completely close the air control.

It is always more difficult to keep the glass clean when running the stove very slowly for long periods.

If blackening of the glass still occurs check that all flue connections and the blanking plate are well sealed. It is also important that the flue draw is sufficient and that it is not affected by down-draught. When the flue is warm a draught reading of at least 1.25 mm (0.05 in.) water gauge (12Pa) should be obtained. Some blackening of the glass may occur below the level of the fuel retainer. This will not obscure the view of the fire or affect its performance.

Fume Emission

Warning Note: Properly installed and operated this appliance will not emit fumes. Occasional fumes from de-ashing and re-fuelling may occur. Persistent fume emission is potentially dangerous and must not be tolerated. If fume emission does persist, then the following immediate actions should be taken:

- a) **Open doors and windows to ventilate the room and then leave the premises.**
- b) **Let the fire out and safely dispose of the fuel from the appliance.**
- c) **Check for flue or flue blockage, and clean if required.**
- d) **Do not attempt to re-light the fire until cause of fuming has been identified, if necessary seek professional advice.**

The most common cause of fume emission is a flue blockage. For your own safety the flue must be kept clean

Fire blazing out of control

Check that:

- a) The door is tightly closed.
- b) The air control slider is fully closed.
- c) A suitable fuel is being used.
- d) Door seals and air slide are intact.

Flue Fires

If the flue is thoroughly and regularly swept, flue fires should not occur. However, if a flue fire does occur close the air control, and tightly close the door of the appliance. This should cause the flue fire to go out in which case the controls should be kept closed until the stove has gone out. The flue should then be cleaned. If the flue fire does not go out when the above action is taken then the fire brigade should be called immediately. After a flue fire the chimney should be carefully examined for any damage. Expert advice should be sought if necessary

IF YOU NEED FURTHER HELP

If you need further help with your Charnwood then your Installer will be able to provide the answers to most questions. Your Local Charnwood Dealer has a great deal of experience and will also be able to provide helpful advice. Further help is available from Pivot Stove & Heating who will be pleased to give advice, if necessary.



UNPACKING THE STOVE

The stove arrives bolted and strapped to its pallet. There must be adequate facilities for unloading and manoeuvring into position. The wrapping is first removed, then the stove released from the pallet by removing 4 pallet bolts using a 10mm spanner. The pallet brackets can now be removed from the stove by tilting it and using a 13mm spanner to remove the bolts. The bolts should be refitted and used for levelling the stove. The pallet is intended to be cut up and used for kindling fuel.

HEALTH AND SAFETY PRECAUTIONS

Please take care when installing the stove.

Ideally there should not be an extractor fan fitted in the same room as the appliance. If this situation is unavoidable then specialist advice should be taken to ensure that the extractor fan does not cause the appliance to emit fumes into the room. The external air kit will help with this in some situations. Alternatively, an additional air supply correctly positioned may be necessary. It is essential to carry out a spillage test to ensure that the appliance can operate safely when the extractor fan is operating.

There must be an adequate air supply into the room in which the appliance is installed to provide combustion air. The combustion air supply must be via a permanently open vent. The requirement for minimum free area is partly dependent on the design air permeability of the house. In older properties the air permeability will be above $5.0\text{m}^3/(\text{h}\cdot\text{m}^2)$, but in some modern properties it may be less. The vent must be positioned such that it is not liable to blockage. Minimum areas are given in the following table:

AIR PERMEABILITY $\text{m}^3/(\text{h}\cdot\text{m}^2)$	MINIMUM VENT AREA $\text{cm}^2(\text{in}^2)$
	ARC 7
>5.0	11 (1.76)
<5.0	38.5 (6.0)

A fixed ducted air supply may be used as an alternative to the traditional method of using a permanent open vent into a room to supply air for combustion.

External air supply kits are available please contact Charnwood for more information. Instruction sheet ref: TIS 120

It is recommended that a carbon monoxide alarm is installed

in the same room as the appliance, in accordance with the alarm manufacturer's instructions.

SPECIFICATION

SPECIFICATION	ARC 7
Fuel	Wood logs
Maximum average heat output burning hardwood:	5kW
Overall average efficiency burning hardwood:	70%
Particulate emissions factor:	0.8g/kg

FLUE

In order for the appliance to perform satisfactorily the flue must give sufficient draw when warm (minimum of 12pa/0.05" wg). The height of the flue must comply with local building regulation requirements. The internal dimensions of the flue **MUST NOT BE LESS THAN 150mm (6")**.

The listed flue's construction and installation must comply with the requirements of AS/NZS2918:2018 and must also meet local building codes. The flue must be suitable for burning solid fuel, lined in good condition and at least 4.6m in height from the base of the appliance. The flue and all its component's must be installed according to the manufacturer's instructions. The flue exit requirements of AS/NZS2918:2018 are 1000mm above the roof and 600mm above any projection within 3000mm, see flue clearances diagram (page 15). This stove is not suitable for use in a shared flue system.

It is important that there is sufficient draw in the flue and that the flue does not suffer from down-draught. When the flue is warm the draw should be not less than 1.25mm (0.05") water gauge (12 Pa). If in doubt about the chimney seek expert advice.

HEARTH AND FIRE SURROUND

The stove must stand on a fireproof hearth and must not be situated closer than the minimum distance from combustible materials to the sides or rear above hearth level unless adequately fireproofed in accordance with local building regulations. If installed on a combustible floor, floor protection must be provided in the form of a non-combustible material to the minimum specifications described in the 'minimum distances to combustibles' section (pages 12 - 14)

INSTALLATION INSTRUCTIONS



When the fire door is open, it extends beyond the flat front of the stove by 450mm.

If in doubt as to the positioning of the stove, expert advice should be sought either from the supplier or the local building inspector. The fireplace must allow good circulation of air around the appliance to ensure that maximum heat is transferred to the room and also to prevent the fireplace from overheating. A gap of 150mm (6") each side and 300mm (12") above the appliance should give sufficient air circulation. If a wooden mantelpiece or beam is used in the fireplace it should be a minimum of 460mm (18"), and preferably 600mm (24") from the appliance. In some situations it may be necessary to shield the beam or mantelpiece to protect it.

In order for the fire to operate correctly the rear air inlet must not be obstructed.

The appliance should be installed on a floor with adequate load-bearing capacity. If an existing construction does not meet this requirement then please take suitable measures to achieve this. (e.g. load distributing plate.)

CONNECTIONS TO FLUES

The Arc 7 must be connected to the flue using flue pipe of 150mm (6") diameter : and is tested for both Air Cooled triple Skin Flue Kits & Room Seal Insulated flue Kits that have been tested to AS/NZS2918:2018

Horizontal lengths of flue must be kept to a minimum and should not be more in length than the flue diameter.

The stove comes with the blanking plate (fig. 7) fitted to the rear flue outlet. The seal for the top outlet is a 155mm dia ring of rope seal. The seal for the rear outlet is a length of adhesive backed fibre webbing supplied with instructions ref: TIS093. This is applied to the flue collar or the Vertical Rear Flue adapter for rear outlet installations.

The top outlet connection is made directly to the cast top of the Arc 7, the Arc 7 is supplied with a flue collar for rear outlet installations.

PRE LIGHTING CHECK

Ensure that the baffle and upper baffle is fitted in the roof of the appliance. For location and positioning see Fig. 6.

Check that the front fence is fitted correctly and that the door closes properly.

COMMISSIONING

Ensure that the rear heatshield extension is fitted to the back of the heatshield (part 010/BPA170) with 2 x 12mm self tapping screws.

This part must be supplied and fitted to the stove. On completion of the installation allow a suitable period of time for the fire cement and mortar to dry out before lighting the fire. Make a layer of ash or sand on the base of the stove before lighting. Check to ensure that smoke and fumes are taken from the appliance up the flue and emitted safely. Also check all joints and seals. On completion of the installation and commissioning please leave the operating instructions with the customer and advise them on the use of the appliance.

COOKING PLATE

010/BP150S - 6 inch kit used on the Arc 7

The kit comprises of a cooking plate and four trivets and can only be fitted to the stove if a rear flue connection is made.

Fig. 7. Flue Blanking Plate.

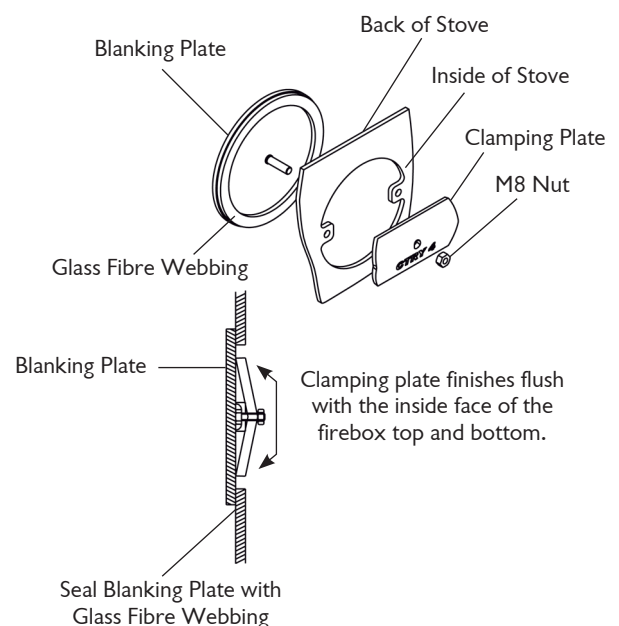



PARALLEL POSITION

CORNER POSITION

COMBUSTIBLE WALLS

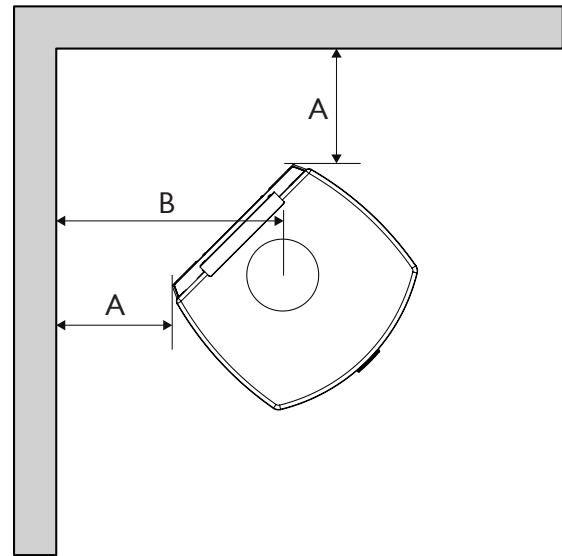
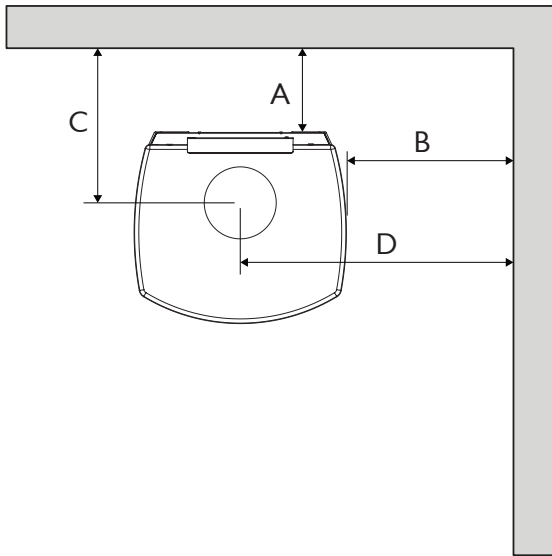

ARC 7 STORE STAND/ LOW

Standard Clearance

- A 200mm*
- B 400mm
- C 366mm
- D 651mm

Corner Clearance

- A 275mm
- B 527mm

* Distance 'A' can be reduced to 100mm if the heat shield extension (*BPA170*) is fitted to the heat shield. This would reduce distance 'C' to 266mm.

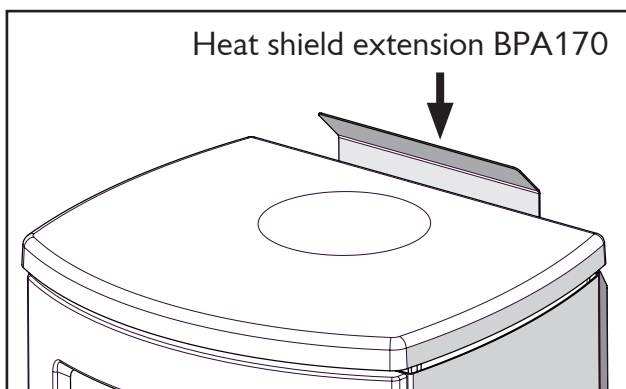

Note: The safe distance to combustibles figures quoted here were achieved using a **Room Seal Flue Kit**.

CLEARANCES WITH REAR FLUE ADAPTOR



PARALLEL POSITION

CORNER POSITION

COMBUSTIBLE WALLS

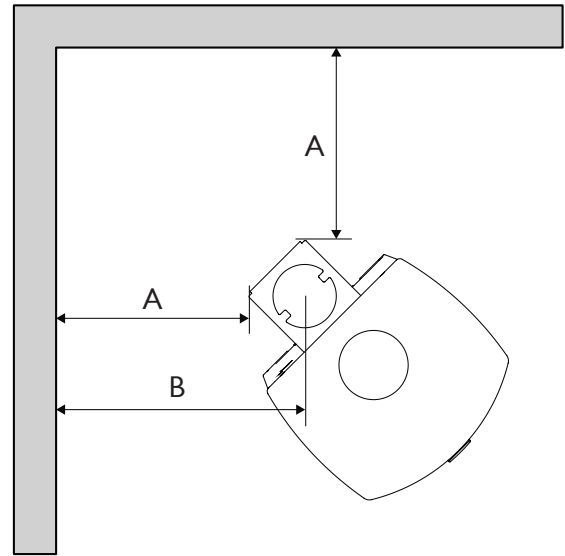
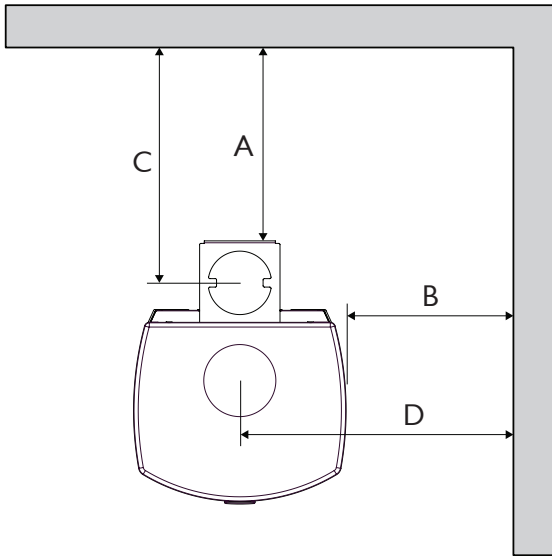

ARC 7 STORE STAND/ LOW

Standard Clearance

A	457mm
B	400mm
C	556mm
D	651mm

Corner Clearance

A	457mm
B	589mm

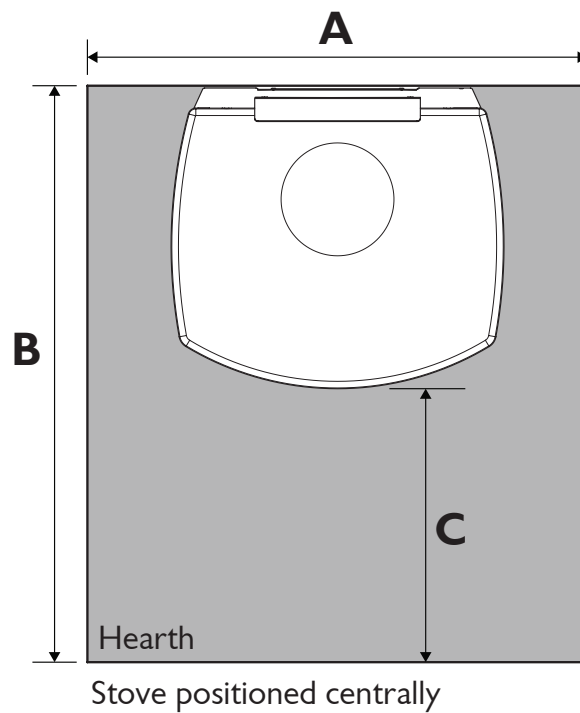

ARC 7 STORE STAND/ LOW

MIN. DIMENSIONS DEFAULT HEARTH

- A 755mm
- B 870mm
- C 420mm

NON-COMBUSTIBLE MATERIAL

Minimum thickness: 6mm

Minimum thermal resistivity: $0.026\text{m}^2\text{K/W}$

Installed in accordance with AS/NZS 2918:2018 3.3.2

FLUE CLEARANCES DIAGRAM



Summary of minimum height of flue system exit requirements from AS/NZS 2918:2018

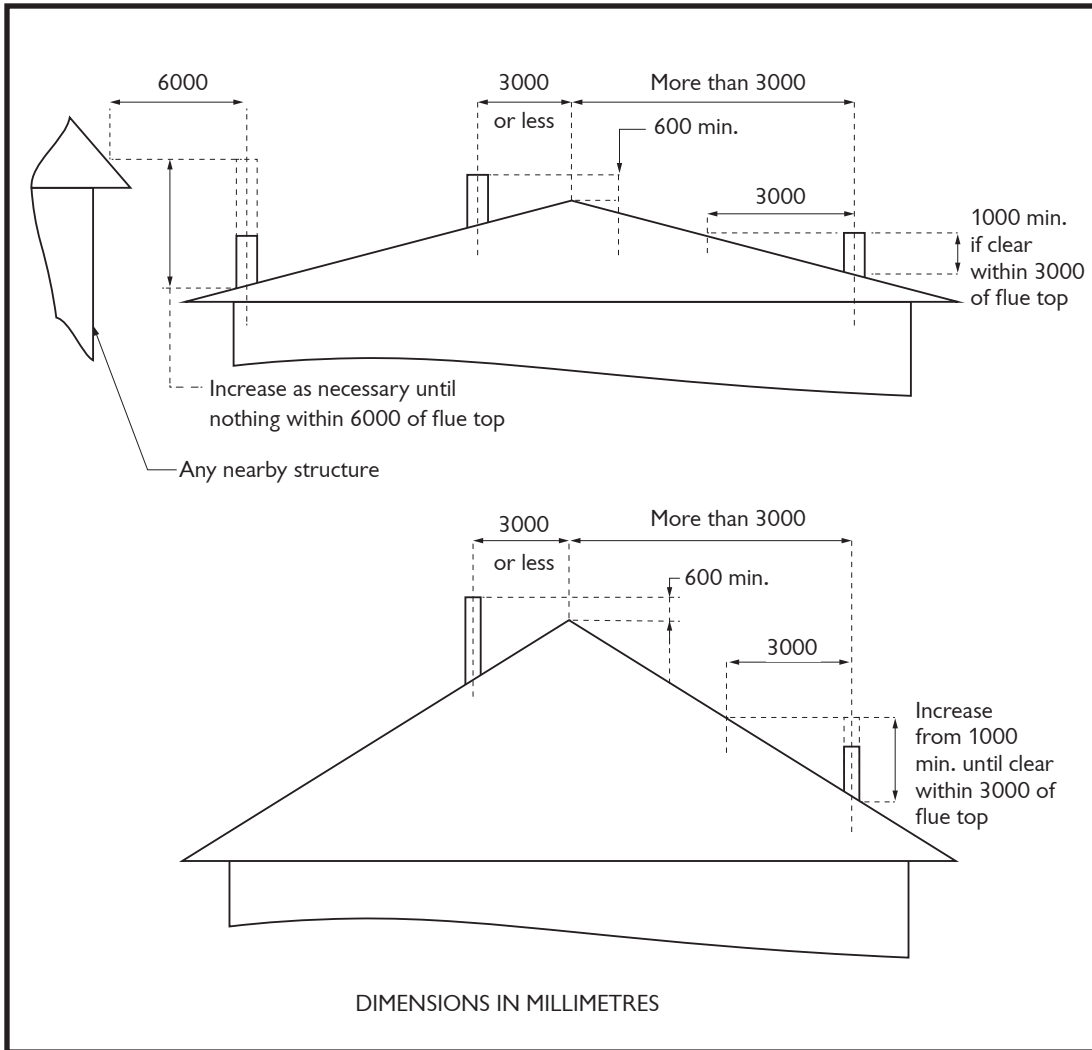

STANDARD DEFAULT TRIPLE SKIN FLUE KIT

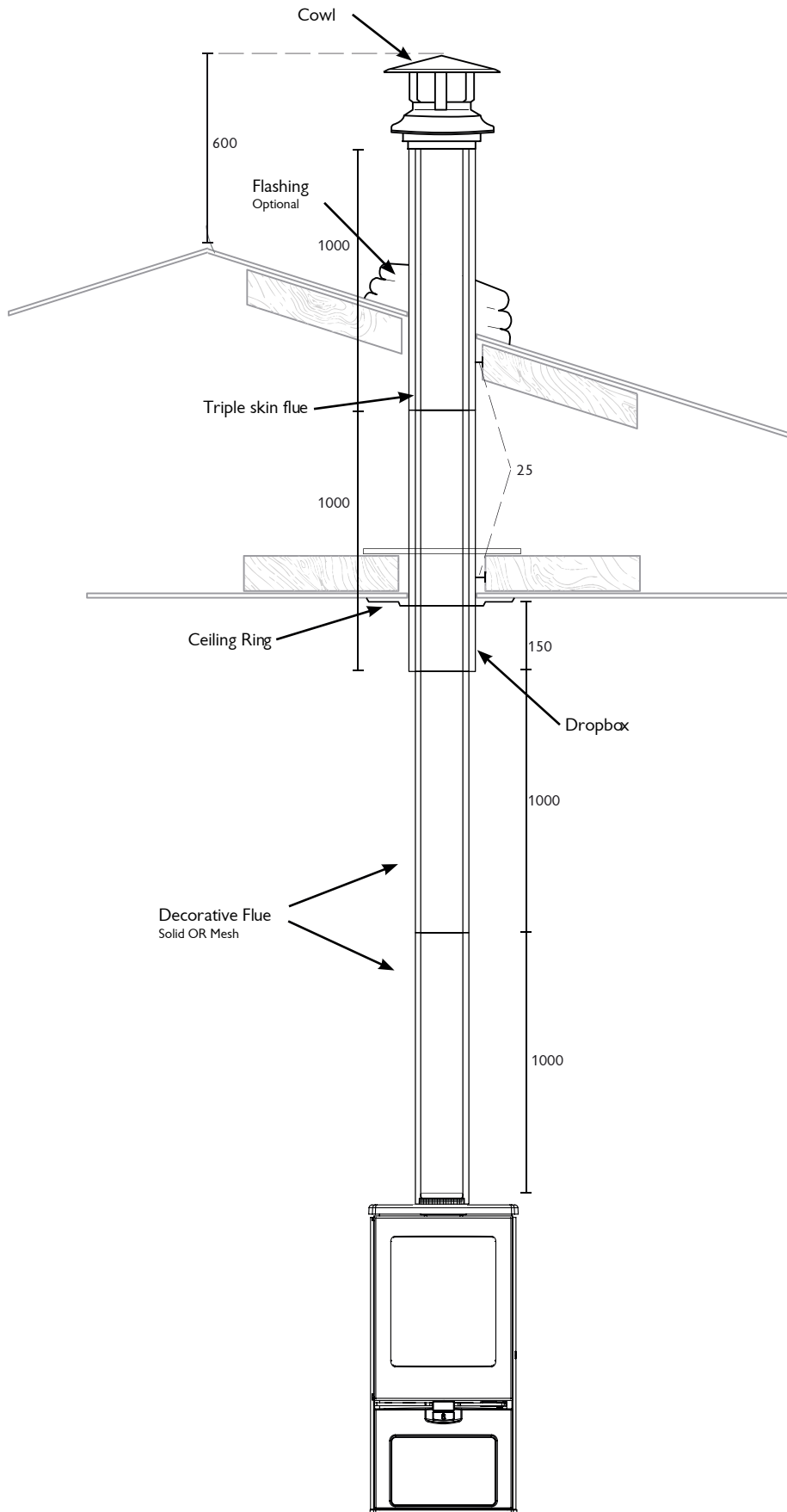

INSULATED ROOM SEAL FLUE KIT



STANDARD FLUE KIT

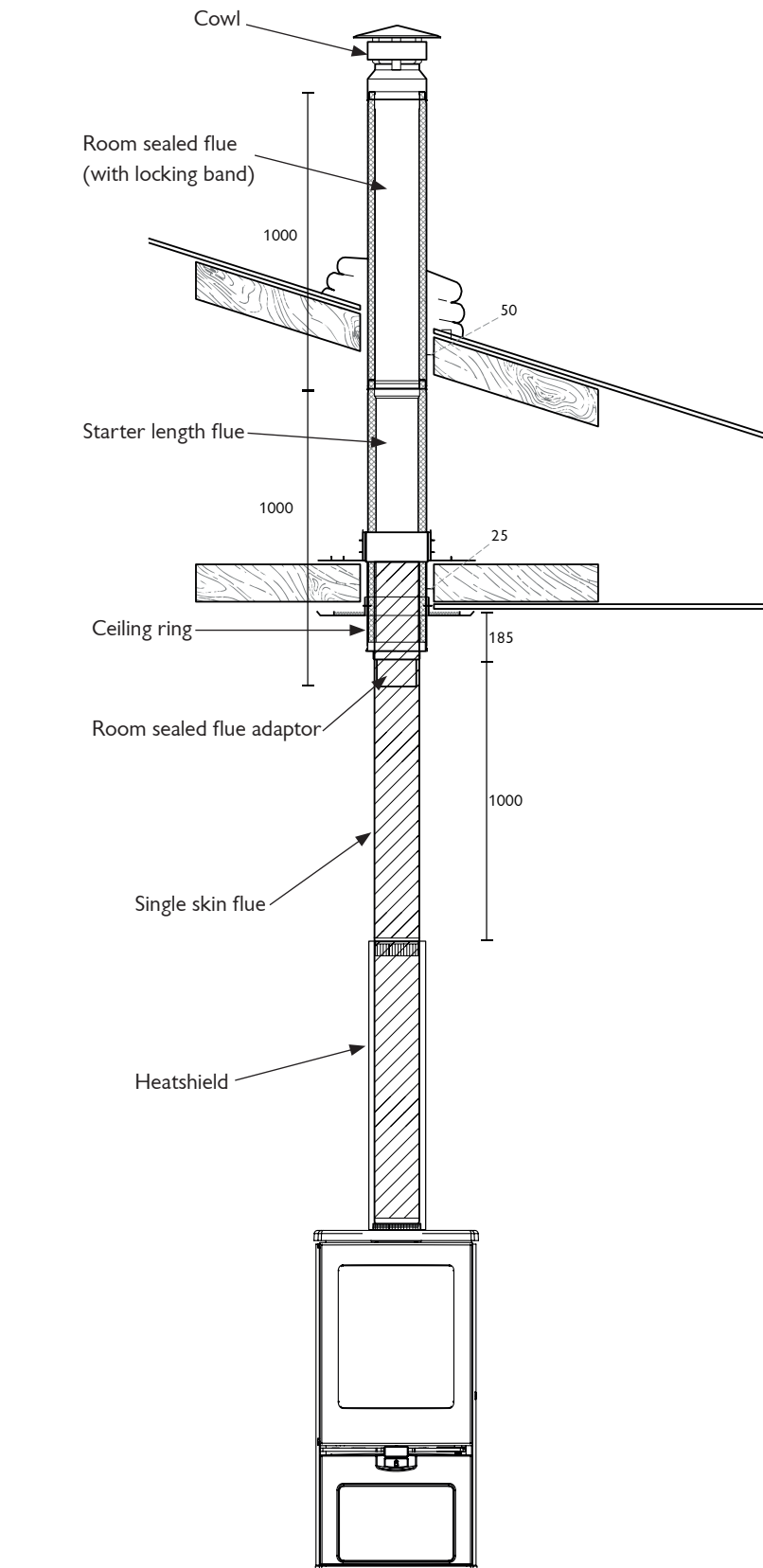

INSULATED ROOM SEAL FLUE KIT



FULLY SEALED FLUE KIT

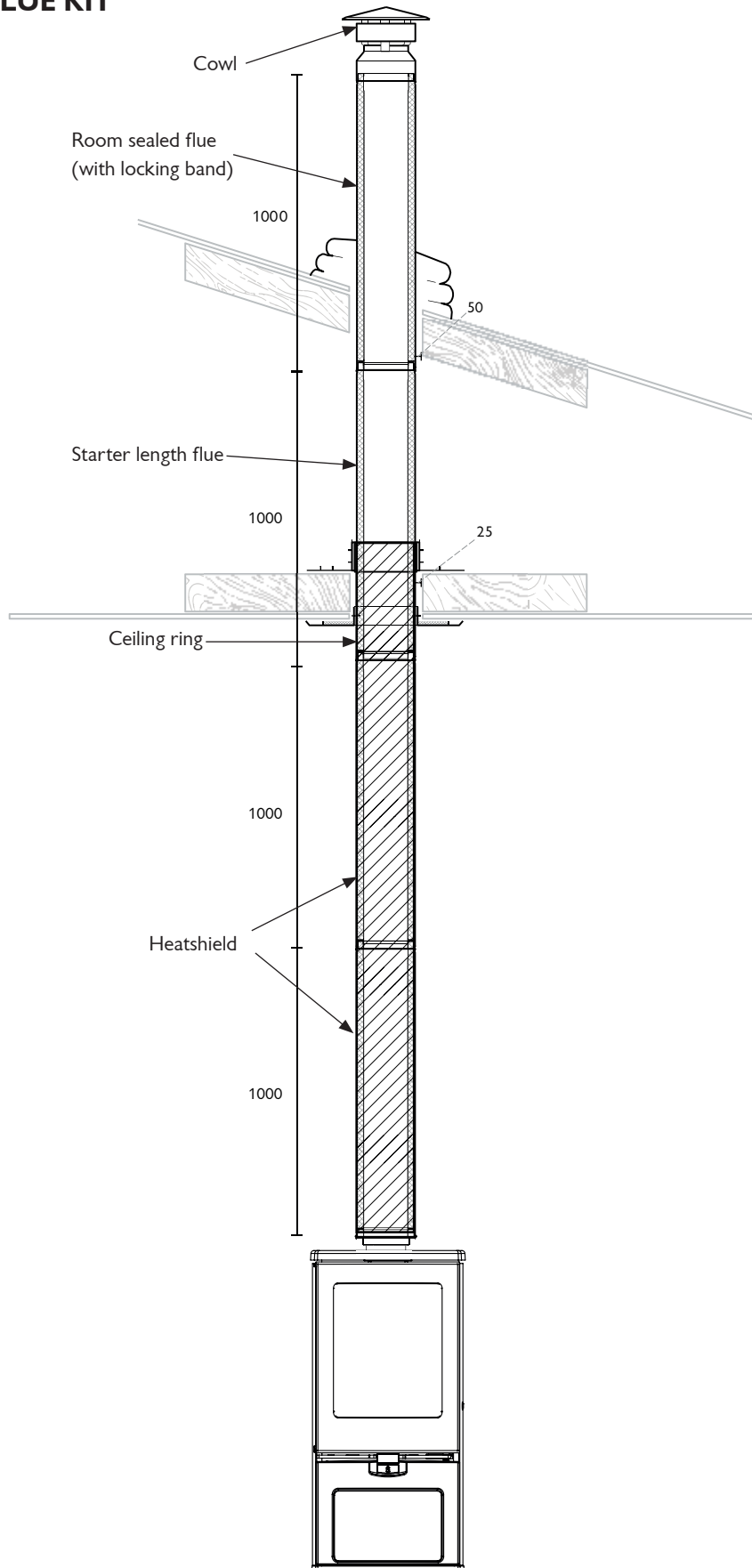

INSULATED ROOM SEAL FLUE KIT



REAR FLUE KIT

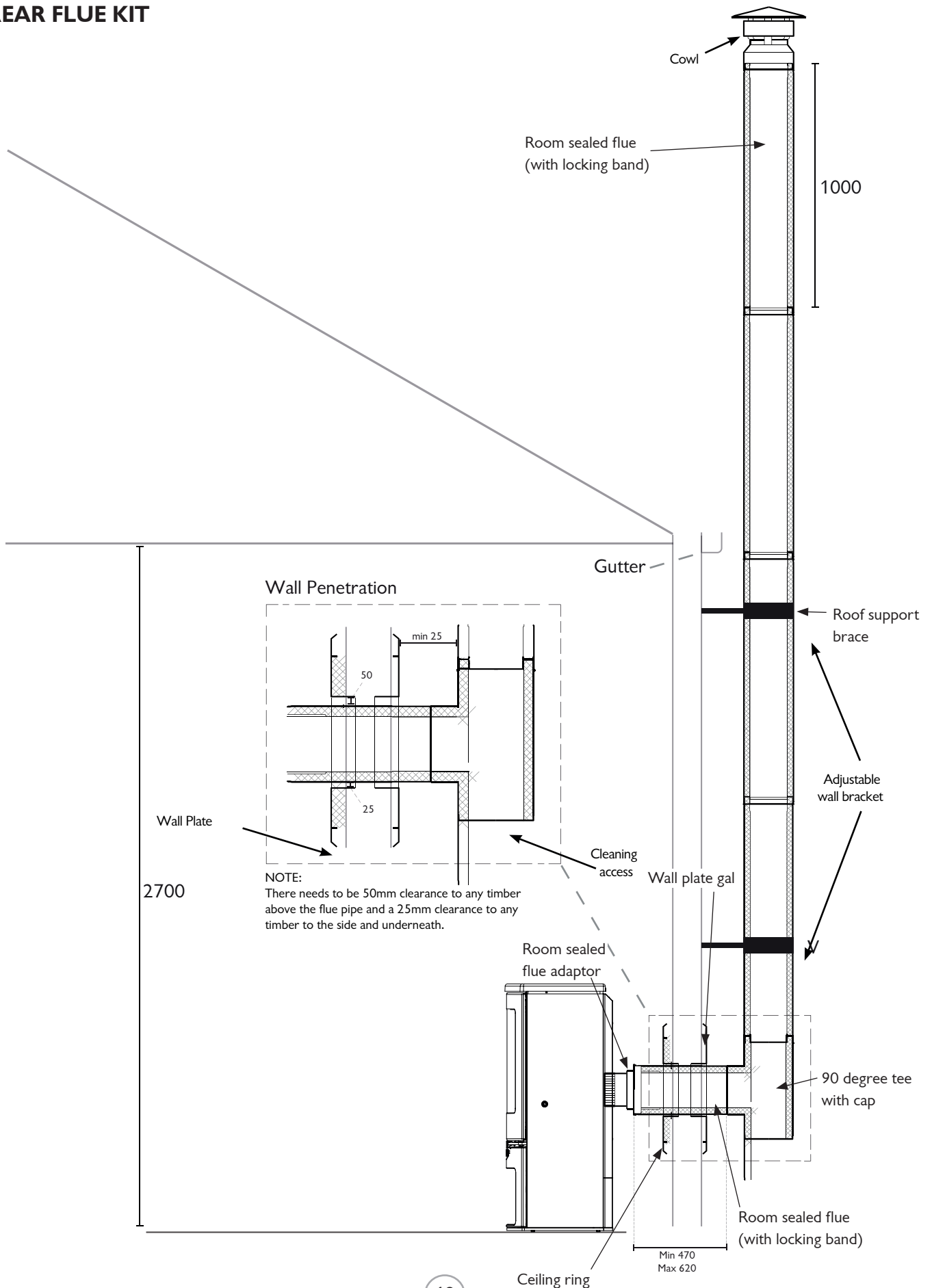

COMPLIANCE DATA



ARC 7 - COMPLIANCE DATA



CHARNWOOD
NEWPORT, IW
PO30 5WS, UK

WWW.CHARNWOOD.COM

DISTRIBUTED BY:

PIVOT STOVE & HEATING CO
120 VICTORIA ST,
NORTH GEELONG VIC 3215,
AUSTRALIA

ONLY USE RECOMMENDED FUELS.

This wood heater needs periodic inspection and repair for proper operation. Consult the operating & installation manual for minimum clearance distances from combustibles. No catalytic combustor. Follow the users instructions.

TESTED BY:	ASFT
TEST REPORT NO:	ASFT20107-1
TESTED TO:	AS/NZS 4012/4013 (2014)
DATE:	05/11/2020

MODEL:	Arc 7
MODEL CODE:	KZA/KZLA
TYPE:	Freestanding

MAXIMUM AVERAGE HEAT OUTPUT BURNING HARDWOOD:	5kW
OVERALL AVERAGE EFFICIENCY BURNING HARDWOOD:	70%
PARTICULATE EMISSIONS FACTOR:	0.8g/kg

Compliance plate riveted onto rear heatshield

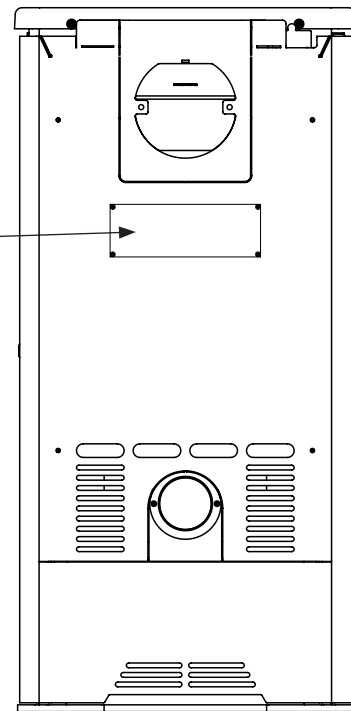

ARC 7 DIMENSIONS

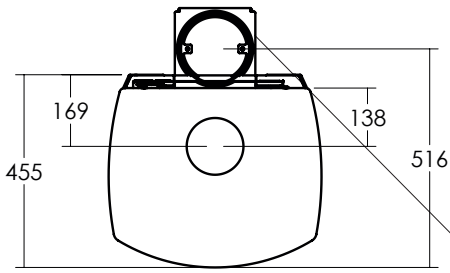

PLAN VIEW

Optional rear flue adaptor

To suit 150mm (6") flue pipe

LOW STAND

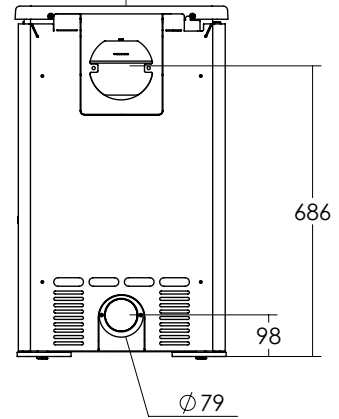
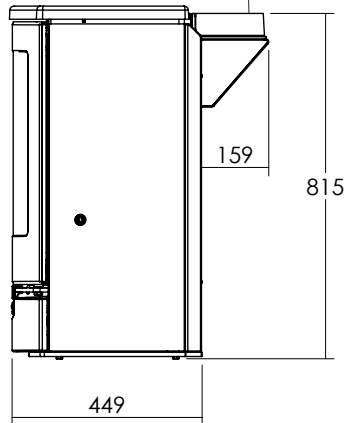
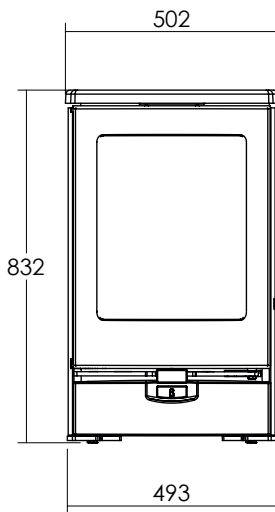

STORE STAND

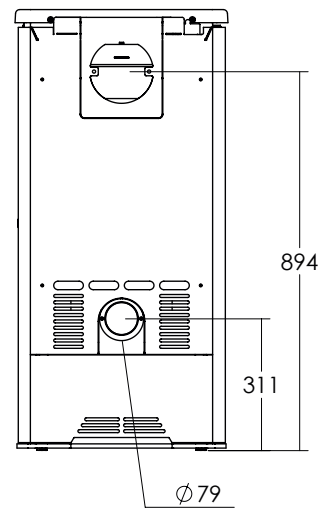
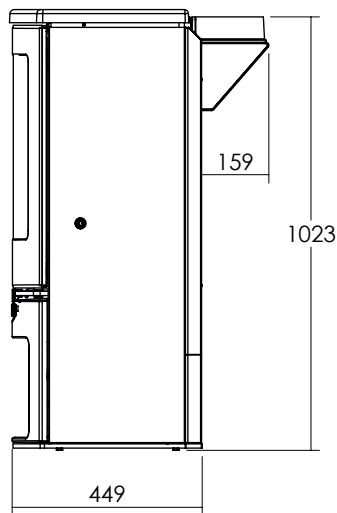
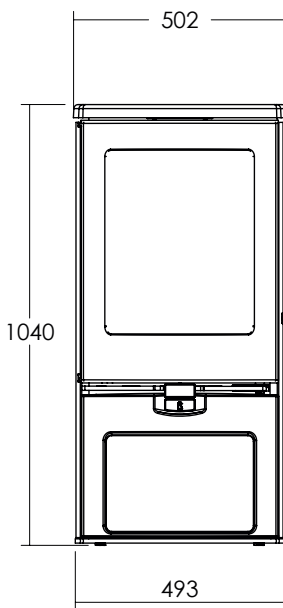

FRONT

SIDE

REAR

Charnwood Arc 7 Australia Parts List

Issue A

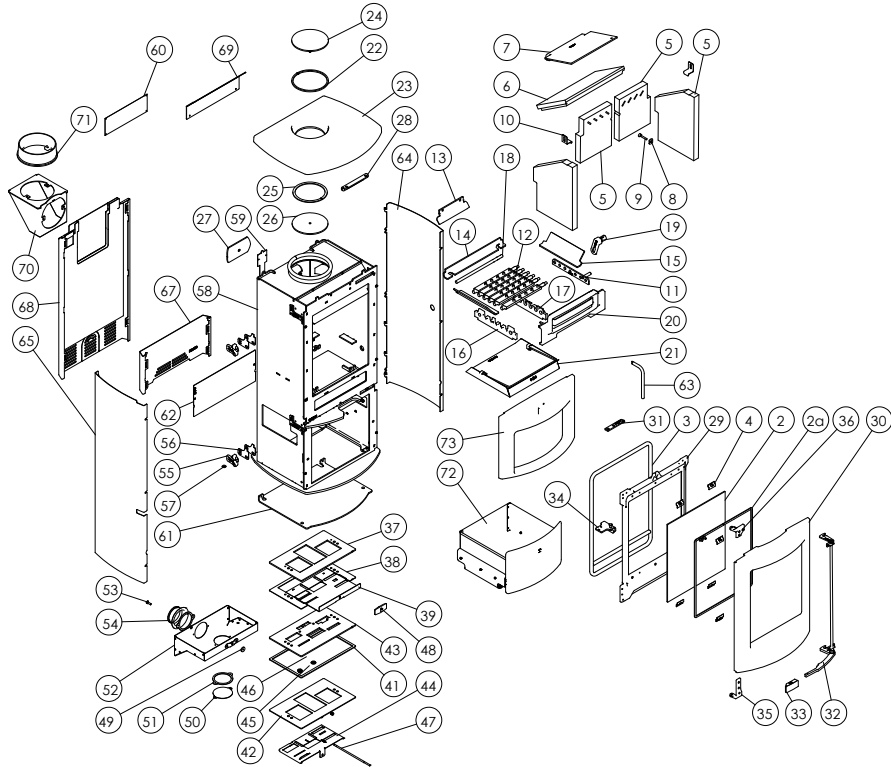

Item	Part No.	Description	Item	Part No.	Description
1*	008/FW29	Door Seal Adhesive	37	010/KZ044	Air Control Slider Backing Plate
2	006/KZ018	Glass Inc. Seal	38	004/KZ043	Wood/Multifuel Surround Plate
2a	008/KZ024	Glass Seal	39	004/KZ045	Slider Wood/Multifuel
3	008/KZ074/S	Door Rope Inc. Adhesive	40	004/EZ014	Wood/Multifuel Selection Lever
4	004/EZ023	Glass Retainer	41	008/KZ006	Airbox Gasket
5	011/KZ029S	Fire Brick Set (4)	42	008/KZ047	Slider Control Gasket
6	011/KZ031	Brick Throat Plate	43	010/KZ005	Air Control Plate
7	010/KZ032	Upper Baffle Plate	44	004/KZ020	Air Slide
8	010/ER036	Brick Retaining Washer	45	004/BR015	Clicker Retainer Plate
9	008/FFB125	Coach Bolt M6 x 45	46	008/ES36/01	Brass Ball Catch
10	004/XV30	Brick Bracket	47	004/EZ016	Control Rod
11	010/KZ083	Mover Bar	48	008/EZ105	Air Control Handle
12	002/CG0156	Set of Grate Bars (6)	49	008/BR052	Felt Washer
13	010/EZ013	Undergrate Ash Deflector	50	004/CR064	Blanking Plate
14	010/KZ080	Rear Fire Plate	51	008/CR063	Blanking Plate Gasket
15	010/KZ079	Side Fire Plate	52	004/KZ039	Air Box Cover
16	002/SY30	LH Carrier Bar	53	008/FFS062	Defra Stop
17	002/EZ077	RH Carrier Bar	54	004/CR048	Air Inlet Spigot
18	012/FW14	Idler Rod	55	002/KZ065	Door Hinge Bracket
19	002/EZ098	Riddler Knob	56	004/KZ066	Door Hinge Shim
20	002/KZ007	Front Fence	57	008/FFW024	M8 Brass Washer
21	004/KZ017	Ashpan	58#	001/KZ010	Firebox
22#	010/KZ131	Flue Pipe Surround Ring	59	012/KZA011	Serial Label
23#	002/KZ009	Cast Top	60	012/KZA180	Compliance Plate
24	010/KZ132	Blanking Plate	61	010/KZ099	Stand Baseplate
25	008/KS134	Flue Sealing Gasket	62	004/KZ078	Stand Backplate
26	010/KZ133	Blanking Plate Retainer	63	004/EZ095	Riddler/ Ashpan Operation Tool
27	010/AY51	Clamping Plate	64#	004/KZ093R	Right Side Panel
28	010/EZ012	Top Retaining Bracket	65#	004/KZ093L	Left Side Panel
29	002/KZ003	Door Back Plate	66*	010/EW51	Ash Carrier (Optional Extra)
30#	002/KZ001/A	Door Casting	67#	004/KZ102	Lower Heatshield
31	010/EZ061	Upper Latch Receiver Plate	68#	010/KZ103A	Upper Heatshield
32#	010/KZ058	Lock Linkage Assembly	69	010/BPA170	Heatshield Extension
33	008/EZ106	Door Handle	70#	010/TW33	Vertical Rear Flue Adapter (Optional Extra)
34	010/KZ064	Lower Latch Receiver Plate	71#	002/CH12B	Flue Collar
35	002/KZ053	Lower Hinge Bracket	72#	010/KZ120	Drawer (Optional Extra)
36	002/KZ054	Upper Hinge Bracket	73#	002/KZ071A	Store Stand Casting

*These items are not shown on the drawing.
Please specify colour when ordering.

To obtain spare parts please contact your local stockist giving Model, Part No. and Description. In case of difficulty contact the manufacturer at the address shown. This drawing is for identification purposes only.

Charnwood Arc 7 Low Australia Parts List

Issue A

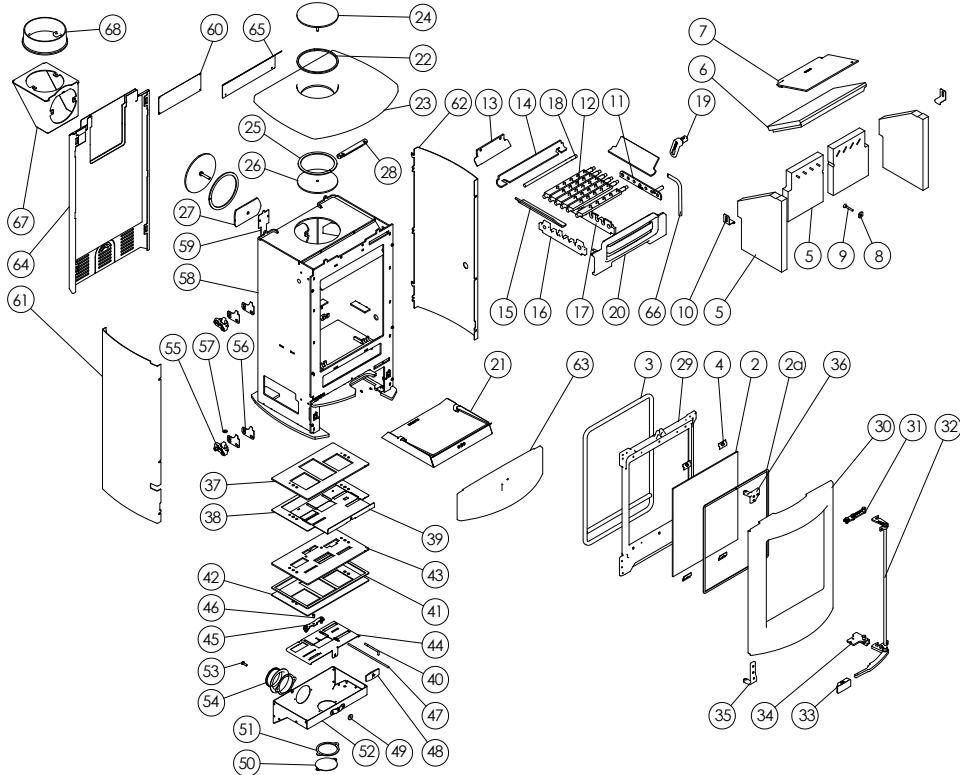

Item	Part No.	Description	Item	Part No.	Description
1*	008/FW29	Door Seal Adhesive	35	002/KZ053	Lower Hinge Bracket
2	006/KZ018	Glass Inc. Seal	36	002/KZ054	Upper Hinge Bracket
2a	008/KZ024	Glass Seal	37	010/KZ044	Air Control Slider Backing Plate
3	008/KZ074/S	Door Seal Kit Inc Adhesive	38	004/KZ043	Wood/Multifuel Surround Plate
4	004/EZ023	Glass Retainer	39	004/KZ045	Slider Wood/Multifuel
5	011/KZ029S	Fire Brick Set (4)	40	004/EZ014	Wood/Multifuel Selection Lever
6	011/KZ031	Brick Throat Plate	41	008/KZ006	Airbox Gasket
7	010/KZ032	Upper Baffle Plate	42	008/KZ047	Slider Control Gasket
8	010/ER036	Brick Retaining Washer	43	010/KZ005	Air Control Plate
9	008/FFB125	Coach Bolt M6 x 45	44	004/KZ020	Air Slide
10	004/XV30	Brick Bracket	45	004/BR015	Clicker Retainer Plate
11	010/KZ083	Mover Bar	46	008/ES36/01	Brass Ball Catch
12	002/CG0156	Set of Grate Bars (6)	47	004/EZ016	Control Rod
13	010/EZ013	Undergrate Ash Deflector	48	008/EZ105	Air Control Handle
14	010/KZ080	Rear Fire Plate	49	008/BR052	Felt Washer
15	010/KZ079	Side Fire Plate	50	004/CR064	Blanking Plate
16	002/SY30	LH Carrier Bar	51	008/CR063	Blanking Plate Gasket
17	002/EZ077	RH Carrier Bar	52	004/KZ039	Air Box Cover
18	012/FW14	Idler Rod	53	008/FFS062	Defra Stop
19	002/EZ098	Riddler Knob	54	004/CR048	Air Inlet Spigot
20	002/KZ007	Front Fence	55	002/KZ065	Door Hinge Bracket
21	004/KZ017	Ashpan	56	004/KZ066	Door Hinge Shim
22#	010/KZ131	Flue Pipe Surround Ring	57	008/FFW024	M8 Brass Washer
23#	002/KZ009	Cast Top	58#	001/KZL010	Firebox
24	010/KZ132	Blanking Plate	59	012/KZLA011	Serial Label
25	008/KS134	Flue Sealing Gasket	60	012/KZLA180	Compliance Plate
26	010/KZ133	Blanking Plate Retainer	61#	004/KZL093L	Left Side Panel
27	010/AY51	Clamping Plate	62#	004/KZL093R	Right Side Panel
28	010/EZ012	Top Retaining Bracket	63#	002/KZL090A	Front Casting
29	002/KZ003	Door Back Plate	64#	004/KZ103A	Heatshield
30#	002/KZ001/A	Door Casting	65	010/BPA170	Heatshield Extension
31	010/EZ061	Upper Latch Receiver Plate	66	004/EZ095	Riddler/ Ashpan Operation Tool
32#	010/KZ058	Rod Handle Assembly	67#	010/TW33	Vertical Rear Flue Adapter (Optional Extra)
33	008/EZ106	Door Handle	68#	002/CH12B	Flue Collar
34	010/KZ064	Lower Latch Receiver Plate	69*	010/EW51	Ash Carrier (Optional Extra)

*These items are not shown on the drawing.
Please specify colour when ordering.

To obtain spare parts please contact your local stockist giving Model, Part No. and Description. In case of difficulty contact the manufacturer at the address shown. This drawing is for identification purposes only.



Issue A

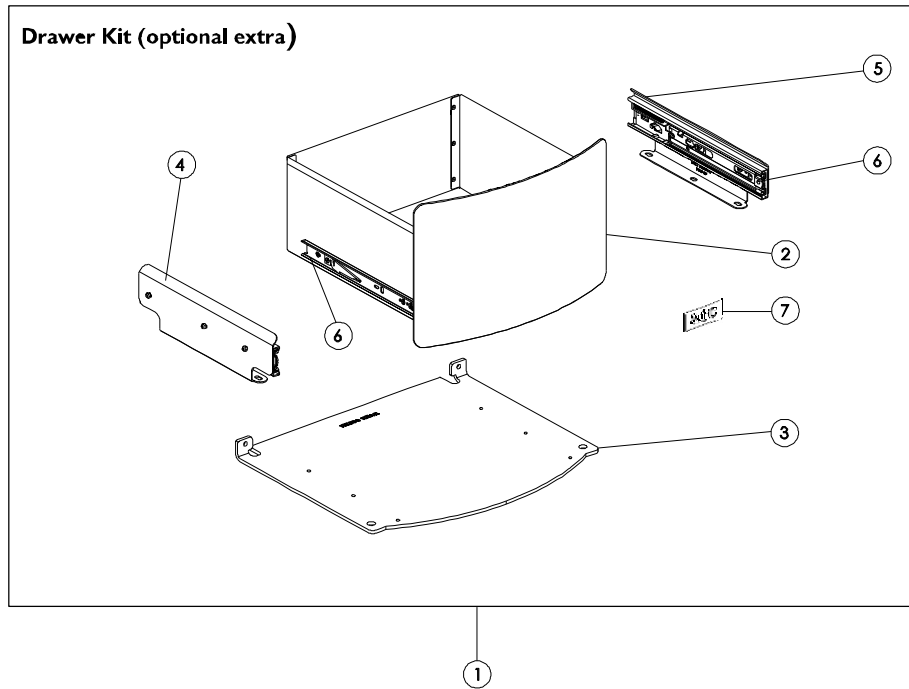

Item	Part No.	Description	Ex.Vat.	Inc.Vat.	Item	Part No.	Description	Ex.Vat.	Inc.Vat.
1#	010/KZ120	Drawer Kit (Optional Extra)	290.00	348.00	5	004/KZ129R	RH Drawer Support	16.90	20.28
2#	010/KZ127	Drawer	NA		6	008/EZ124	Drawer Slide Runner	16.10	19.32
3	010/KZ096	Drawer Base Plate	36.00	43.20	7	008/EZ130	Adhesive Plastic Label	6.35	7.62
4	004/KZ129L	LH Drawer Support	16.90	20.28					

Prices are shown in pounds sterling with vat at 20% They are correct at the date shown but may be subject to change without notice. E. & O.E

To obtain spare parts please contact your local stockist giving Model, Part No. and Description. In case of difficulty contact the manufacturer at the address shown. This

CHARNWOOD AUSTRALIA 10 YEAR GUARANTEE



To register your 10 Year Stove Guarantee please visit or scan QR:

www.charnwood.com/my-stove/guarantees/

and enter the following code: CGG-AUS

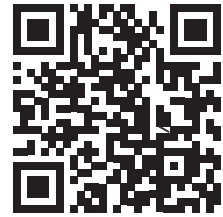

TERMS AND CONDITIONS

10 Year Warranty: The firebox of your Charnwood Stove is guaranteed against material and manufacturing defect for a period of 10 years

1 Year Warranty: The consumable items such as bricks, rope seal and associated parts are guaranteed for a period of 1 year.

- The guarantee registration form must be completed online and submitted within 14 days of purchase to enable the guarantee to be activated.
- The following conditions apply:
- If any part fails due to manufacturing or material defect within the guarantee period Charnwood will, free of charge, either repair or replace the part at their discretion. The decision of Charnwood is final.
- This guarantee is for parts only.
- Charnwood will not be liable for any consequential loss or incidental loss, damage or injury however caused.
- This guarantee will become void if the appliance: is not installed in accordance with the installation instructions; is not regularly serviced in accordance with the installation instructions; is subject to misuse or neglect, including the use of non-recommended fuel; or if repairs or modifications have been carried out by anyone other than Charnwood or their official representatives.
- All claims on this guarantee must be made through the supplier of the appliance and must be accompanied by proof of purchase.
- Nothing in this guarantee shall affect your statutory rights.

EXCLUSIONS AND LIMITATIONS

This Guarantee does not cover the following:

- Charnwood will not be liable for any consequential loss or incidental loss, damage or injury however caused.
- This guarantee will become void if the appliance is not installed by a suitably qualified and is not installed in accordance with the AS.NZS 2918
- This guarantee will become void if the appliance is not installed in accordance with the installation instructions and is not regularly serviced, in accordance with the installation instructions.
- If the product is subject to misuse or neglect, including the use of non-recommended fuels.
- If repairs or modifications have been carried out by anyone other than Charnwood or their authorised representatives.
- Damage caused by over-firing of the stove. Please refer to our operating instructions for further details.
- Damage caused by storing or using the product in a damp environment. Corrosion caused by condensation, damp or water ingress into the flue, chimney or the surrounding of the stove.
- Defects or faults caused by local conditions such as draught problems and chimney defects.
- The paint finish will require touching up or repainting from time to time. Maintaining the finish is normal practice and is not covered by the guarantee.

your premier dealer

charnwood BISHOPS WAY, NEWPORT, ISLE OF WIGHT PO30 5WS, UNITED KINGDOM
TEL. +44 (0) 1983 537777 • FAX. +44 (0) 1983 537788 • WWW.CHARNWOOD.COM

A Division of A.J. Wells & Sons Limited Registered in England No. 03809371